

Serial Concatenation of Space-Time and Recursive Convolutional Codes

Young-Jo Ko and Jung-Im Kim

ABSTRACT— We propose a new serial concatenation scheme for space-time and recursive convolutional codes, in which a space-time code is used as the outer code and a single recursive convolutional code as the inner code. We discuss previously proposed serial concatenation schemes employing multiple inner codes and compare them with the new one. The proposed method and the previous one with joint decoding, both performing a combined decoding of the simultaneous output signals from multiple antennas, give a large performance gain over the separate decoding method. In decoding complexity, the new concatenation scheme has a lower complexity compared with the multiple encoding/joint decoding scheme due to the use of the single inner code. Simulation results for a communication system with two transmit and one receive antennas in a quasi-static Rayleigh fading channel show that the proposed scheme outperforms the previous schemes.

I. INTRODUCTION

Space-time codes combining forward error correction coding and antenna diversity have attracted great attention since Foschini and Gans showed a remarkable increase in capacity by using multiple transmit and receive antennas [1]. Tarokh et al. [2] proposed the design criteria for space-time codes for flat Rayleigh fading channels. In conventional error-correction coding for single-antenna communication systems, the concatenations of two convolutional codes with an interleaver in between, known as “turbo codes,” provide a significant coding gain [3]. Recently, several concatenation schemes have also been proposed for multiple-antenna systems [4]-[6]. A

serial concatenation proposed by Lin and Blum [4] employed a space-time code as the outer code and multiple recursive convolutional codes as the inner code. They used a separate decoding scheme for each multiple inner code, whereas Yim et al. [6] used a decoding scheme which jointly decodes all the simultaneous output symbols from the inner encoders. No direct performance comparison has been made between the two decoding schemes. Further, joint decoding may be too complex to implement despite its possibility of better performance.

In this work, we propose a new encoding/decoding structure for the serial concatenation of space-time and recursive systematic convolutional (RSC) codes. A single RSC code is employed as the inner code, which produces all symbols to be transmitted simultaneously over multiple transmit antennas. Simulations for two transmit and one receive antennas in a quasi-static, flat Rayleigh fading channel show that the new scheme gives significantly better performance than the original multiple coding/separate decoding scheme [4]. As compared with joint decoding [6], the new scheme proposed in this paper achieves slightly better performance, while maintaining a lower complexity.

II. ENCODER/DECODER STRUCTURE

The model communication system considered here has n transmit and m receive antennas. In the encoding/decoding structure suggested by Lin and Blum [4], the space-time trellis code proposed in [2] is taken to be the outer code and recursive convolutional codes to be the inner code. The analysis of serially concatenated convolutional codes shows that the inner code should be a recursive convolutional code with a large effective free distance and the outer code should be non-recursive with a large free distance [10]. The data is first

Manuscript received Aug. 3, 2002; revised Nov. 6, 2002.

Young-Jo Ko (phone: +82 42 860 4810, e-mail: koj@etri.re.kr) is with Basic Research Laboratory, ETRI, Daejeon, Korea.

Jung-Im Kim (e-mail: jungim@etri.re.kr) is with Mobile Telecommunication Research Laboratory, ETRI, Daejeon, Korea.

encoded by the outer encoder, which produces n output streams. The output streams are interleaved, further encoded by the inner encoders independently, and then fed into the modulator. In the modulator, the output symbol streams from the inner encoders are separately mapped onto constellation points for transmission over different transmit antennas. At each time k , the output of the modulator is a signal $(c_1^k, c_2^k, \dots, c_n^k)$, where c_i^k is transmitted using transmit antenna i . The received signal r_j^k at antenna j at time k is given by

$$r_j^k = \sum_{i=1}^n \alpha_{i,j} c_i^k + \eta_k^j,$$

where the fading coefficient $\alpha_{i,j}$ for transmission from transmit antenna i to receive antenna j and the noise η_k^j at time k are independent samples of a zero-mean complex Gaussian random variable with variance 0.5 and $N_0/2$ per dimension, respectively. The coefficients $\alpha_{i,j}$ are constant during each frame transmission and change independently from one frame to another.

The three concatenation schemes use the iterative decoding technique. The inner (outer) soft-input soft-output (SISO) maximum a posteriori (MAP) decoder updates the MAP probabilities of the input (output) symbols of the inner (outer) code. The three schemes use different algorithms in the inner SISO MAP decoder.

1. Multiple Encoding and Separate Decoding

Lin and Blum used an inner SISO MAP decoder consisting of n inner decoders, in which each inner decoder computes the a priori probabilities of the input symbols of the individual inner encoders using SISO algorithms [4]. Here we apply the original BCJR algorithm as formulated in [7]. Each inner code has its own trellis structure, contains no parallel transitions, and produces symbols independently of the other encoders. In each inner decoder, the branch measures for state transitions of the corresponding inner code are calculated. Assuming that d_i^k is the input to inner encoder i at time k , the branch measure $\gamma_k(s_i^{k-1}, s_i^k)$ for the transition from state s_i^{k-1} to s_i^k at time k in inner encoder i is calculated as follows.

$$\gamma_k(s_i^{k-1}, s_i^k) = P(r_1^k, \dots, r_m^k | c_i^k) P(d_i^k) \quad (1)$$

if $P(d_i^k | s_i^{k-1}, s_i^k) = 1$.

To exploit the modulator output directly, we can use

$$P(r_1^k, \dots, r_m^k | c_i^k) = \sum_{c^k: c_i^k = c_i^k} P(r_1^k, \dots, r_m^k | c_1^k, \dots, c_n^k) P(c_1^k, c_2^k, \dots, c_n^k), \quad (2)$$

where the summation is taken over all possible configurations of $C^k = \{c_1^k, \dots, c_n^k\}$ under constraint $C_i^k = c_i^k$. As in [4], $c_1^k, c_2^k, \dots, c_n^k$ are assumed to be independent of each other and $P(c_1^k, c_2^k, \dots, c_n^k)$ is decomposed as follows.

$$P(r_1^k, \dots, r_m^k | c_i^k) = \sum_{c^k: c_i^k = c_i^k} P(r_1^k, \dots, r_m^k | c_1^k, \dots, c_n^k) P(c_1^k) P(c_2^k) \dots P(c_n^k), \quad (3)$$

where $P(r_1^k, \dots, r_m^k | c_1^k, \dots, c_n^k)$ can be obtained from the demodulator output using the following equation,

$$P(r_1^k, \dots, r_m^k | c_1^k, \dots, c_n^k) = \prod_{j=1}^m \frac{1}{\sqrt{\pi N_0}} \exp \left[-\frac{\left| r_j^k - \sum_{i=1}^n \alpha_{i,j} c_i^k \right|^2}{N_0} \right]. \quad (4)$$

In (3), each inner decoder requires as input the probability distribution of the output symbols from all the other encoders, which are taken to be equally probable over signal constellation points. In the multi-encoding/separate-decoding method of [4], because all the output symbols from the inner encoders are mixed by simultaneous transmission over multiple antennas, the above decomposition and summation process is required to compute the branch measures for each inner decoder.

2. Multiple Encoding and Joint Decoding

In the joint decoding scheme, the n separate encoders are treated as a whole and the inner SISO MAP decoder is a single decoder, which incorporates all the n input/output independent symbols into a single trellis structure. This decoder structure does not require the probability distribution of the individual output symbols from the encoders and thus is expected to give a better decoding performance than the separate decoding structure. In the joint decoding scheme, the inner encoders are treated as independent elements of a larger single encoder. Decoding is done for all possible combinations of symbols from the n inner encoders. The state of the combined encoder at time k , s^k may be written as $s^k = (s_1^k, \dots, s_n^k)$. The input and output of the combined encoder at time k may be written as $d^k = (d_1^k, \dots, d_n^k)$ and $c^k = (c_1^k, \dots, c_n^k)$, respectively. Now, the branch measure for the combined encoder is given as the following form using the demodulator output of (4):

$$\Gamma_k(s^{k-1}, s^k) = P(r_1^k, \dots, r_m^k | c_1^k, \dots, c_n^k) P(d_1^k) P(d_2^k) \dots P(d_n^k). \quad (5)$$

The disadvantage of the joint decoding is that the number of trellis states of the combined encoder is given by the product of

the numbers of the individual inner encoder states, easily leading to an excessively large number of trellis states.

3. Proposed Scheme: Single Encoding and Decoding

The new encoding and decoding schemes are shown in Fig. 1(a) and 1(b), respectively. The characteristic feature of the proposed encoding/decoding scheme is that only one RSC encoder is used as the inner encoder, which simplifies the decoding process without sacrificing performance as will be shown later. The data encoded by the outer code is interleaved and put into a parallel-to-serial converter. The output stream of the converter is encoded further by the inner encoder and then it is fed into a serial-to-parallel converter. In our scheme, the output symbols of the inner encoder that are produced by inputting the symbols from a particular output stream of the space-time encoder are all directed to the same transmit antenna. Once the code rate of the inner code is chosen, such one-to-one correspondence between the output streams of the space-time encoder and the transmit antennas can be maintained by properly choosing the units of the parallel-to-serial and the serial-to-parallel conversion. For example, if the code rate of the inner code is p/q , where p and q are integers with no common divisors, the units of the parallel-to-serial and the serial-to-parallel conversion are taken to be p and q bits, respectively. Our simulations indicate that the full diversity order of the space-time code is preserved under this constraint, as found by comparing the slopes of FER versus SNR curves (Fig. 2). However, in general cases with other encoders and different numbers of antennas, this mapping constraint alone may not be enough to maintain the full diversity order of the outer space-time code.

The advantage of the use of a single inner encoder lies in its simplicity in decoding compared with the joint decoding scheme. Here the decoding complexity is compared between the multiple encoding/joint decoding and the single encoding/decoding schemes. Assume that we use a rate 1/2, binary RSC encoder as the inner encoder and QPSK modulation. In our scheme, for combined decoding of n input bits to the inner encoder, we construct a new trellis diagram that outputs n QPSK symbols each transition based on the trellis diagram of the RSC encoder. The n consecutive sections of the original trellis diagram for the RSC code are folded into one effective section to produce n consecutive output symbols per state transition. The folding of the trellis section does not change the number of trellis states; the number of transition branches per state, however, increases to 2^n . Thus, the total number of transition branches in the code is given by (the number of trellis states in the RSC code) $\times 2^n$. In comparison, in the multiple encoding/joint decoding scheme with the same RSC code, the number of trellis states of the combined code is

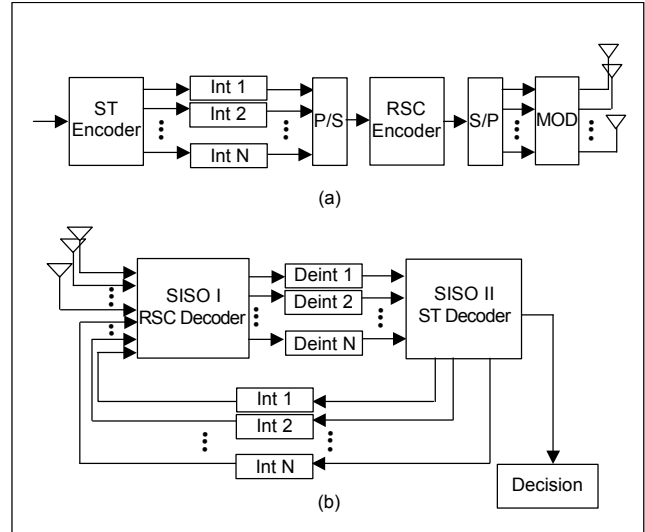

Fig. 1. Serial concatenation of space-time and recursive convolutional codes: (a) block diagrams of the proposed encoder structure, (b) decoder structure.

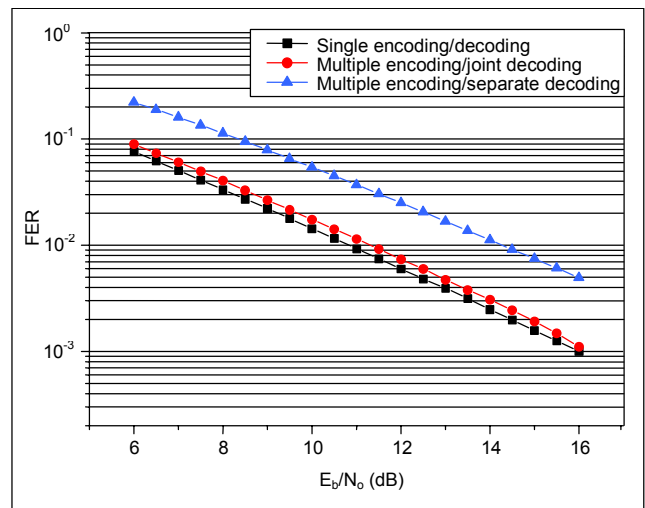

Fig. 2. Performance comparison of serial concatenations of space-time and recursive convolutional codes: two transmit and one receive antennas, quasi-static, flat Rayleigh fading channel, 4-state Tarokh et al. space-time trellis code (outer code), rate-1/2 binary RSC code (inner code), with spectral efficiency of 1bps/Hz, 240 information bits per frame, 15 iterations.

given by (the number of trellis states in the single RSC encoder)ⁿ and the number of transition branches per state is 2^n . Thus, the number of transition branches in the combined code amounts to (the number of trellis states in the RSC code)ⁿ $\times 2^n$. For example, if we use a 4-state, rate 1/2, binary RSC code as the inner encoder and two transmit antennas, the resulting trellis for two QPSK symbols has 4 states and 4 transition branches per state while, in the joint decoding, it has 16 states and 4 transition branches per state.

The branch measure in the single-decoder scheme is calculated using the same form as (5) but, now with d_i^k 's and c_i^k 's being the consecutive input and output symbols of the single encoder, respectively, which makes it possible to directly use the demodulator output of (4) without the additional decomposition and summation process required in the multiple encoding/separate decoding scheme [4].

III. SIMULATION RESULTS

We compare the performance of the three serially concatenated space-time codes under a quasi-static, flat-fading channel environment. The 4-state space-time trellis code in [2] is taken as the outer code and a rate 1/2, 4-state RSC code as the inner code. The RSC code has the constraint length 3 and the feedforward and feedback generating polynomials are given by (5, 3) in octal. For iterative SISO MAP decoding, the BCJR algorithm reformulated in log domain [8] is used. The simulation is performed for two transmit and one receive antennas with QPSK modulation. The corresponding spectral efficiency is 1 bps/Hz. The frame length is set at 240 bits. A perfect knowledge of the channel is assumed at the receiver. Figure 2 shows the FER performances of the three encoding/decoding schemes. The single encoding/decoding scheme reveals far better performance than the original serial concatenation employing the multiple inner encoders and decoders. Its performance is even slightly better than the most complex joint decoding scheme.

In both the multiple encoding/joint decoding and the single encoding/decoding methods, independence between the interleaved output symbols of the space-time encoders d_1^k, \dots, d_n^k is assumed. The same assumption for d_1^k, \dots, d_n^k is also implied in the probability decomposition in (3) between the output symbols of the inner encoders $c_1^k, c_2^k, \dots, c_n^k$ in the multiple encoding/separate decoding method. We note that this assumption is only approximately valid since the simultaneous outputs of the space-time codes are correlated to each other. Since the above independence assumption is made in all three methods, it is not considered to be the main cause for the performance difference. The performance gain of the multiple encoding/joint decoding and the single encoding/decoding methods over the original scheme mainly comes from the combined decoding of all the simultaneous output signals. With the combined decoding, both schemes avoid the need of the probability distributions of the individual symbols of $c_1^k, c_2^k, \dots, c_n^k$. On the other hand, in the multiple encoding/separate decoding scheme, each inner decoder computes the branch measure for its own symbol by summing over all possible configurations with the assumption of the uniform probability distributions of the individual symbols of

$c_1^k, c_2^k, \dots, c_n^k$ from other transmit antennas. This artificial assumption, however, results in a performance loss. One may improve the performance by updating the probability distributions with the introduction of an iterative modulation – decoding algorithm [9].

IV. CONCLUSION

We have proposed a new efficient encoding/decoding structure for serial concatenation of space-time and recursive systematic convolutional codes. Comparison with previous schemes shows that the new concatenation structure can achieve the best performance by performing the combined decoding of simultaneous output symbols from multiple transmit antennas and it enables a decoding algorithm much simpler than the previous scheme with comparable performance by the use of a single RSC code as the inner code.

REFERENCES

- [1] G.J. Foschini and M.J. Gans, "On Limits of Wireless Communications in a Fading Environment When Using Multiple Antennas," *Wireless Personal Communications*, vol. 6, Mar. 1998, pp. 311-335.
- [2] V. Tarokh, N. Seshadri, and A.R. Calderbank, "Space-Time Codes for High Data Rate Wireless Communication: Performance Criteria and Code Construction," *IEEE Trans. Inform. Theory*, Mar. 1998, pp. 744-764.
- [3] C. Heegard and S.B. Wicker, *Turbo Coding*, Kluwer Academic Publishers, Boston, MA, 1999.
- [4] X. Lin and R.S. Blum, "Improved Space-Time Codes Using Serial Concatenation," *IEEE Commun. Lett.*, vol. 4, no. 7, July 2000, pp. 221-223.
- [5] D. Tujkovic, "Recursive Space-Time Codes for Turbo-Coded Modulation," *Proc. IEEE GLOBECOM'00*, San Francisco, USA, Nov. 2000, pp. 1010-1015.
- [6] E.J. Yim, D.K. Kim, and H.-Y. Song, "MIMO Iterative Decoding of Serial Concatenation Using Space-Time Trellis Codes," *Electron. Lett.*, vol. 38, no. 4, Feb. 2002, pp. 190-191.
- [7] L. Bahl, J. Cocke, F. Jelinek, and J. Raviv, "Optimal Decoding of Linear Codes for Minimizing Symbol Error Rate," *IEEE Trans. Inform. Theory*, vol. IT-20, Mar. 1974, pp. 284-287.
- [8] P. Robertson, E. Villebrun, and P. Hoeher, "A Comparison of Optimal and Sub-Optimal MAP Decoding Algorithms Operating in the Log Domain," *Proc. IEEE ICC*, Seattle, WA, USA, June 1995, pp. 1009-1013.
- [9] A. Stefanov and T.M. Duman, "Turbo-Coded Modulation for Systems with Transmit and Receive Antenna Diversity over Block Fading Channels: System Model, Decoding Approaches, and Practical Considerations," *IEEE J. Sel. Areas Commun.*, vol. 19, no. 5, May 2001, pp. 958-968.
- [10] S. Benedetto, D. Divsalar, G. Montorsi, and F. Pollara, "Serial Concatenation of Interleaved Codes: Performance Analysis, Design, and Iterative Decoding," *TDA progress report 42-126*, Jet Propulsion Laboratory, Pasadena, California, Aug. 15, 1996.