

Facial Feature Extraction Based on Private Energy Map in DCT Domain

Ki Hyun Kim, Yun-Su Chung, Jang-Hee Yoo, and Yong Man Ro

ABSTRACT—This letter presents a new feature extraction method based on the private energy map (PEM) technique to utilize the energy characteristics of a facial image. Compared with a non-facial image, a facial image shows large energy congestion in special regions of discrete cosine transform (DCT) coefficients. The PEM is generated by energy probability of the DCT coefficients of facial images. In experiments, higher face recognition performance figures of 100% for the ORL database and 98.8% for the ETRI database have been achieved.

Keywords—Face recognition, private energy map, energy probability, discrete cosine transform.

I. Introduction

Feature extraction is one of the most important steps in face recognition, and it usually attempts to reduce the high dimensional data space into the low dimensional feature vector. Dimension reduction of the feature vectors is essential for extracting the effective features and for reducing computational complexity in the classification step. To reduce the dimensionality, the most frequently used techniques are principal components analysis (PCA) and linear discriminant analysis (LDA), but these methods required high computational cost and a large number of training samples. To overcome these problems, the methods for extracting feature vector in the discrete cosine transform (DCT) domain have been studied for the past several years [1], [2].

In this letter, a new feature extraction method based on the

private energy map (PEM) technique to utilize the energy characteristics of a facial image is presented. Using the unique energy characteristics of a facial image improves recognition performance and leads to the dimensional reduction of feature vectors.

This letter is organized as follows. In section II, characteristics of a facial image in the DCT domain is reviewed. Section III describes the energy probability and the method of generating an energy map. Finally, experimental results and conclusion are described in sections IV and V.

II. Characteristics of a Facial Image

In this section, the DCT and characteristics of a facial image in the DCT domain are briefly reviewed.

The first characteristic of facial image is symmetry. In general, a facial image is normalized with rotation, scale, and poses within 10 degrees in a face recognition system. A normalized facial image characteristically has higher values in odd columns than in even columns of a DCT coefficient matrix. That is, the high energy of the DCT coefficients is congested in odd columns rather than in even columns.

The second characteristic of a facial image is frequency. Facial images generally include facial components such as eyes, eyebrows and mouth, which have strong horizontal and vertical frequency properties. In the case of a facial image, the DCT coefficients of high energy are congested in the top-left and top-upper band rather than the diagonal frequency band.

III. Proposed Private Energy Map Algorithm

1. Energy Probability and Private Energy Map

Energy is one of the most important properties in image

Manuscript received Nov. 06, 2006; revised Jan. 29, 2007.

Ki Hyun Kim (phone: +82 42 866 6289, email: kihyun@jcu.ac.kr) was with Information Security Research Division, ETRI, Daejeon, Korea and is currently with Image and Video Systems Lab., ICU, Daejeon, Korea.

Yun-Su Chung (phone: +82 42 860 6579, email: yoonsu@etri.re.kr) and Jang-Hee Yoo (email: jhy@etri.re.kr) are with Information Security Research Division, ETRI, Daejeon, Korea.

Yong Man Ro (email: yro@jcu.ac.kr) is with the School of Engineering, ICU, Daejeon, Korea.

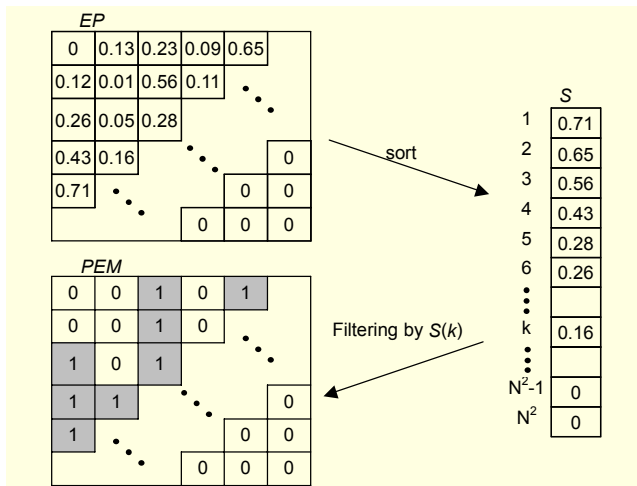

Fig. 1. Generation procedure of PEM.

processing [3]. Given a result of DCT transform on a facial image, $F(u, v)$ with the size $N \times N$, the energy using DCT coefficients is defined as

$$Energy_F = \sum_{u=1}^N \sum_{v=1}^N |F(u, v)|^2, \quad (1)$$

where $Energy_F$ is the only value for the facial image. From the $Energy_F$ and the square value of each coefficient, the energy probability $EP(u, v)$ is defined by

$$EP(u, v) = \frac{|F(u, v)|^2}{Energy_F}. \quad (2)$$

The magnitude of $EP(u, v)$ can be used as a criterion for selecting valid coefficients and it means the relative energy magnitude of each coefficient at position (u, v) . Therefore,

coefficients of high EP value hold more valid information than coefficients with low EP value.

Using (2), a PEM is generated as shown in Fig. 1. Suppose that the width and height of a face image are $N \times N$. The EPs of $N \times N$ size can be calculated by using (1) and (2). Then, the EPs are converted into a column vector S , which is sorted by EP values in descending order. If the k -th value is the threshold, the position of the S values between the first and k -th values will be 1, and other values will be zero:

$$PEM(i, j) = \begin{cases} 1 & \text{if } EP(i, j) \geq S(k), \\ 0 & \text{otherwise.} \end{cases} \quad (3)$$

2. Proposed Approach Based on PEM

The PEM is used to make the input vectors of the LDA and to generate the feature vector in the enrollment and testing procedure.

As shown in Fig. 2, the proposed method consists of three stages: a training stage, an enrollment stage, and a testing stage. First, facial images are transformed by the DCT and a PEM of $N \times N$ size is generated using EPs of the DCT coefficients. Second, the PEM is multiplied with an effective coefficient filter (ECF) to obtain the most invariant feature vector of the facial images ($PEM \cdot ECF$). The ECF controls the number of effective coefficients in the PEM. The ECF is generated by the same method which generated the PEM with the average DCT coefficient matrix of all facial images used in the training process. Finally, W is acquired by LDA of the coefficients extracted with $PEM \cdot ECF$, where W is the LDA optimal projection matrix [4]. The enrollment and testing stages have equal procedures to obtain the feature vector. Enrollment and

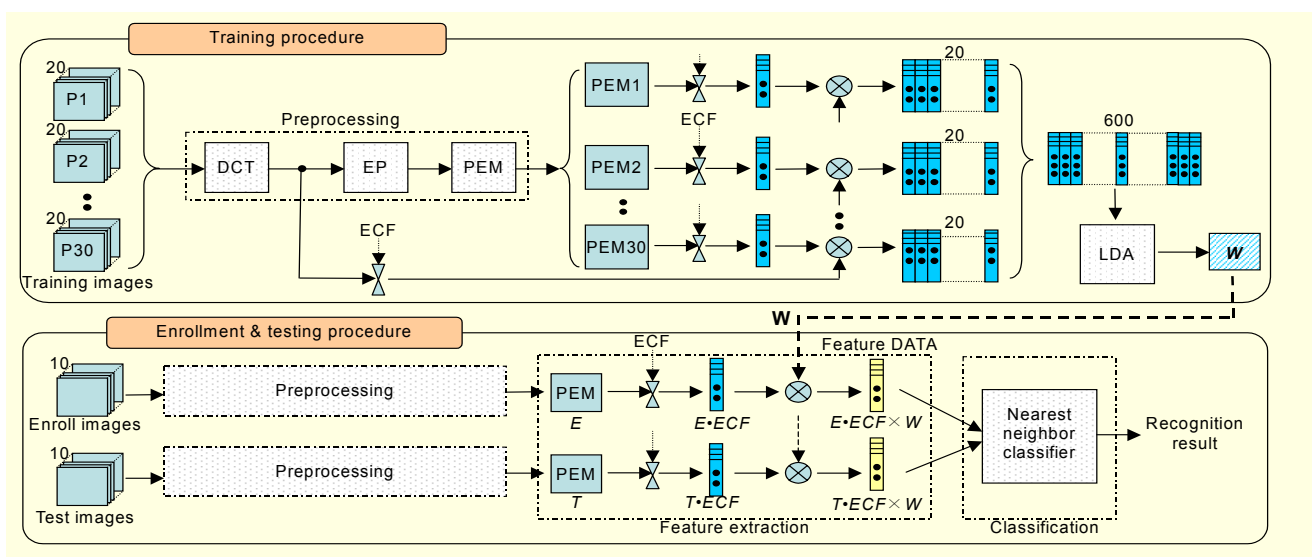

Fig. 2. Block diagram of proposed method.

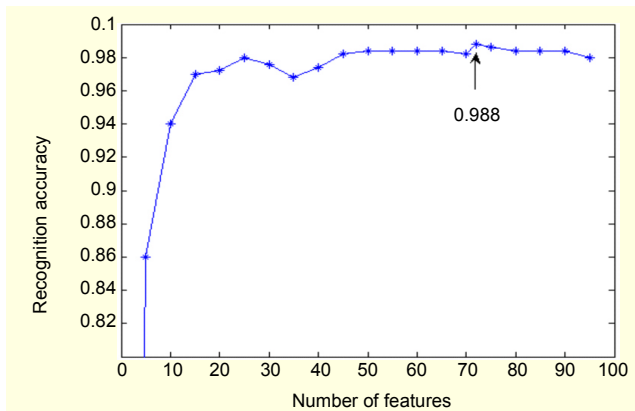

Fig. 3. Recognition accuracy with the number of effective values.

testing images are converted into E and T after being preprocessed. The final feature vectors are established multiplying $E \cdot ECF$, $T \cdot ECF$ and W , which become $E \cdot ECF \times W$ and $T \cdot ECF \times W$. Then, the Euclidian distance between the two vectors is measured, and the system decides whether to “Accept” or “Reject.”

IV. Experimental Results

In our face recognition experiment, the Electronic Telecommunication Research Institute (ETRI) face database and the ORL face database (<http://www.cam-orl.co.uk>) were used. The ETRI face database contains images of 55 different subjects with 10 images of each subject. The ORL database contains 40 subjects with 10 images of each subject.

The number of effective values in the ECF was determined by experiment. Figure 3 shows the experiment result. When the value is 72, recognition is most accurate.

The performance of the proposed method was measured by two error rates: the false rejection rate (FRR) and the false acceptance rate (FAR). Figure 4 shows the Euclidian distances using zigzag scanning and the proposed method. The FAR/FRR curves depend on the Euclidian distance. Therefore, the two error curves have an intersection point. By selecting the cross point of the two error curves as a threshold, the two error rates are minimized at the same time and can be found at 0.038 and 0.012, respectively. The proposed method shows a lower equal error rate (EER) value than the previous method. Figure 4 shows the recognition accuracy according to the number of valid coefficients in the feature vector. The best EER is 0.012 when 38 valid coefficients are used.

We compared the results from the following feature extraction methods: PCA+LAD in a special domain, LDA using zigzag- scanning in the DCT domain, and the proposed method (see Table 1). The proposed method has the best recognition accuracy rates of 98.8% and 100% for the ETRI

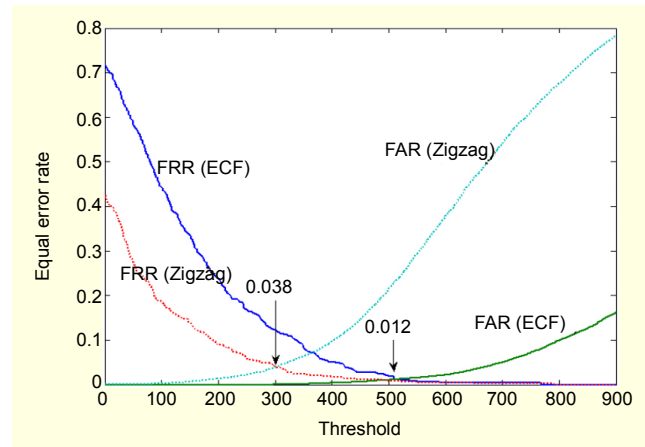

Fig. 4. EERs of proposed method and zigzag scanning.

Table 1. Recognition accuracy (%).

Method DB used	PCA+LDA	LDA	Proposed
ETRI	90	96.2	98.8
ORL	98	99	100

DB and the ORL DB, respectively.

V. Conclusion

A new feature extraction method for face recognition has been presented. The method selects the facial valid coefficients by using a PEM, which is generated by using the energy probability of each DCT coefficient. The valid coefficients are based on facial image characteristics. Then, the feature vector is extracted through LDA analysis on the valid coefficients and compared with the registered vector. The experimental results show that the proposed method shows better face recognition performance than the previous methods.

References

- [1] S.M. Lee, H.J. Bae, and S.H. Jung, “Efficient Content-Based Image Retrieval Method Using Color and Texture,” *ETRI J.*, vol. 20, no. 3, Sep. 1998, pp. 272-283.
- [2] K.H. Choi, J.J. Yoo, and T.H. Hwang, “A Probabilistic Network for Facial Feature Verification,” *ETRI J.*, vol. 25, no. 2, Apr. 2003, pp. 140-143.
- [3] W.K. Pratt, *Digital Image Processing*, John Wiley & Sons, Inc., New York, 2001.
- [4] W. Chen, M.J. Er. and S. Wu, “PCA and LDA in DCT Domain,” *Pattern Recognition Letters*, vol. 26, 2005, pp. 2474-2482.