

# Efficient Generation of Scalable Transport Stream for High Quality Service in T-DMB

Kwang-Yong Kim, Gwang Soon Lee, Jong Soo Lim, Soo In Lee, and Duk Gyo Kim

**ABSTRACT**—We introduce an advanced terrestrial digital multimedia broadcasting (AT-DMB) system that overcomes the limitation of data transmission rates of T-DMB by doubling it with the same frequency bandwidth. In this letter, we propose an efficient algorithm which generates a scalable transport stream in AT-DMB by multiplexing certain types of elementary streams encoded using scalable video coding and an MPEG-surround audio coder for high-quality multimedia services.

**Keywords**—T-DMB, AT-DMB, MPEG-4, SVC, multiplexer

## I. Introduction

Terrestrial digital multimedia broadcasting (T-DMB) [1], [2] is a type of mobile broadcasting technology that has been successfully commercialized in several countries. Despite its benefits including low-cost installation and wide area coverage, it has fewer available services than other technologies due to its low transmission efficiency. To be competitive and to provide a higher-quality multimedia mobile service, it should increase the effective data transmission rate under the existing spectrum band. Advanced T-DMB (AT-DMB) fulfills such requirements while guaranteeing backward compatibility with T-DMB.

## II. Advanced T-DMB System

Figure 1 illustrates a conceptual diagram of the proposed AT-DMB system for a high quality multimedia service, which

specifically includes a scalable media encoder and a hierarchical modulator. The scalable media encoder comprises a scalable video coding (SVC) encoder [3] with quarter VGA (QVGA) and VGA layers, and an MPEG surround audio encoder [4] with stereo and multichannel layers. The newly added data channel shown in Fig. 1 is assured thanks to hierarchical modulation and can transmit additional payload data, enabling a higher quality service than T-DMB. Figure 2 shows the constellation example of hierarchical modulation in AT-DMB. Here, the existing QPSK signal is defined as a high priority (HP) signal adopted from T-DMB, and the newly added QPSK signal is defined as a low priority (LP) signal. These two signals are made up of a hierarchical modulation signal, LP over HP, and are broadcast via the same frequency spectrum as T-DMB. A conventional T-DMB receiver also demodulates and decodes the AT-DMB signal, providing the basic service via an HP channel only. On

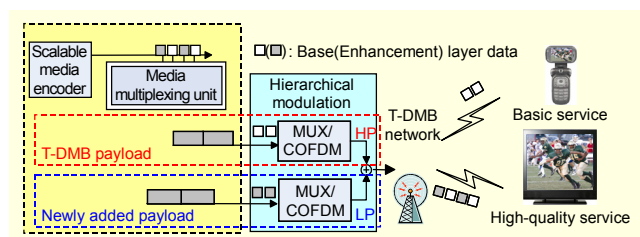

Fig. 1. Conceptual block diagram of AT-DMB.

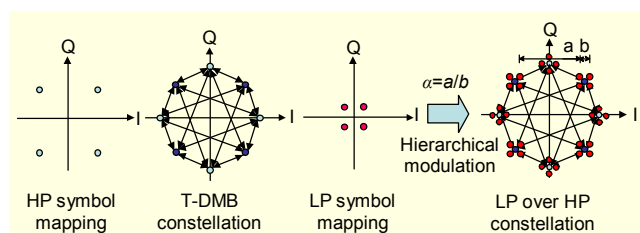

Fig. 2. Constellation of hierarchical modulation in AT-DMB.

Manuscript received July 24, 2008; revised Oct. 29, 2008; accepted Dec. 15, 2008.

This work was supported by the Ministry of Knowledge Economy and Korea Communications Commission under the title of "Development of Advanced Transmission Technology for the Terrestrial DMB System".

Kwang-Yong Kim (phone: + 82 42 860 1628, email: kimky@etri.re.kr), Gwang Soon Lee (phone: + 82 42 860 1676, email: gslee@etri.re.kr), Jong Soo Lim (email: ljten@etri.re.kr), and Soo In Lee (email: silee@etri.re.kr) are with the Broadcasting & Telecommunications Convergence Research Laboratory, ETRI, Daejeon, Rep. of Korea.

Duk Gyo Kim (email: dgkim@knu.ac.kr) is with the School of Electrical Engineering and Computer Science, Kyungpook National University, Daegu, Rep. of Korea.

the other hand, an AT-DMB receiver can provide more services or higher-quality service using the added LP channel. However, for high-quality service, it is necessary first to design a new technique to generate two bit-streams by splitting an elementary stream (ES) at the scalable media encoder. These are then inserted into two ensemble streams and transmitted through the HP and LP channels, respectively.

### III. Media Multiplexer for Advanced T-DMB

There are two important rules in designing the media multiplexer unit. First, the unit has to perfectly maintain backward compatibility with a T-DMB media stream. Second, due to the transmission of a two-layered media stream through a physically independent path, the unit also has to provide an effective synchronization mechanism within the inter-system (TS), inter-media (ES), and inter-layer levels [5].

#### 1. Multiplexer Structure

As shown in Fig. 3, a sync layer/packetized elementary stream (SL/PES) packetizer transforms the received base-layer ESs/SLs pair into base-layer SL/PES packets and the enhancement-layer ESs/SLs pair into enhancement-layer SL/PES packets. While the conventional media multiplexer includes a single TS multiplexer, the proposed media system multiplexer includes two TS multiplexers, a base-layer TS multiplexer and an enhancement-layer TS multiplexer, and multiplexes packetized PES streams and PSI section/14496 section streams into each MPEG-2 TS packet. Finally, a pair of multiplexed MPEG-2 TS packets are independently encoded in respective channel encoders and then transmitted through a single RF channel using hierarchal modulation.

In our system, a single object descriptor (OD) is first created to describe two ES streams, namely, the base and enhancement layers. Then the OD is also split at the OD/BIFS splitter for transmission through respective layers, which makes sense from the viewpoint of backward-compatibility. The dependent relationship among MPEG-4 objects can be expressed using the StreamDependenceFlag and dependsOn\_ES\_ID MPEG-4 ES descriptors. Also, the location of the ES is designated using the URL\_Flag to designate that the ES itself exists in the enhancement layer even though it is described in the same OD as that of the base layer ES.

For the independent base-layer stream, the parameters are set as ObjectypeIndication = 0x21 (AVC) and StreamType = 0x04 (visual stream) according to the conventional MPEG-4 AVC standard. For the enhancement-layer stream, which is dependent on the base-layer stream and is encoded by the SVC encoder, the parameters are set as ObjectypeIndication = 0xC0 (user private), StreamType = 0x04 (visual stream), StreamDependenceFlag = 1,

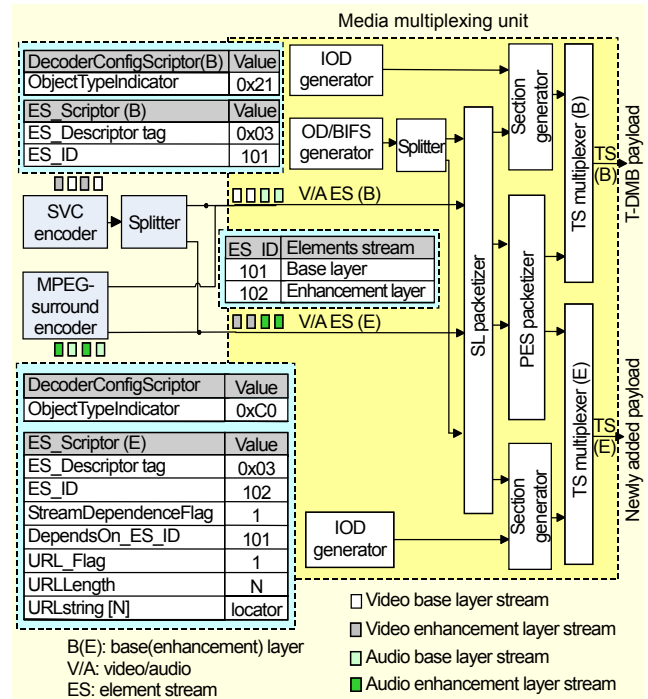

Fig. 3. Block diagram of the media multiplexer.

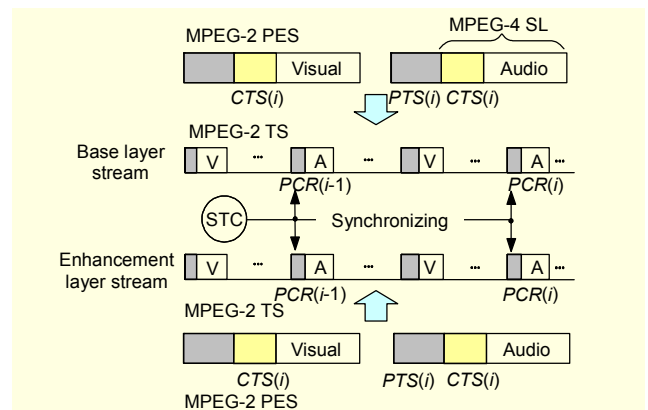

Fig. 4. Synchronization between base and enhancement layers.

and dependsOn\_ES\_ID = 101 (basic layer ES\_ID). To designate that the dependent stream is located at the other transport stream rather than at the enhancement layer, we define URL\_Flag = 1, URL.string [URL.length] = Locator (enhancement layer location).

#### 2. Synchronization between Two Layers

To ensure synchronization between a pair of transport streams, we also propose using the same system time clock (STC) at both multiplexing blocks as shown in Fig 4. That is, program clock references (PCRs) for both multiplexers are generated by a common STC inserted into both MPEG-2 TS packets respectively in order to maintain an identical time base between both layers. Consequently, corresponding audio and video ESs at the base layer and enhancement layer can be

Table 1. Experimental conditions.

		Ensemble 1 (HP)		Ensemble 2 (LP)
		Subch 1	Subch 2	Subch 1
Freq. (bandwidth)		208.736 MHz (1.536 MHz)		
Rate (kbps)	TS	480	544	1,088
	Video/Audio	342/46	384/52	936/52
Service		Service1	Service2	Service 2 (high quality)

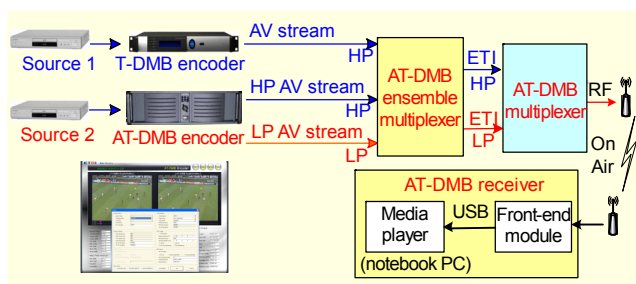

Fig. 5. Configuration of the experimental transmission system.

synchronized thanks to a composition time stamp that is generated by referencing the PCR. With the help of the PCR at both MPEG-2 TSs, some devices including an AT-DMB multiplexer and receiver can maintain two media streams at a concurrent time base. Specifically, the AT-DMB media multiplexer inserts the PCR into only MPEG-TS packets for an audio stream to reduce additional TS packets for carrying the PCR. For this reason, most of the MPEG-2 TS packets for an audio stream are probably not filled with payload data generated at an even point of time. Accordingly, a relevant PTS and OCR are also inserted into only the MPEG-4 SL and MPEG-2 PES for the audio stream.

#### IV. Experimental Result

To verify the proposed method, we implemented an AT-DMB media encoder, which can employ a high quality service through an AT-DMB network as shown in Fig. 1. Actually, based on the proposed method, this encoder platform generates two kinds of transport streams which have functions of the outer encoder (Reed-Solomon encoder and convolutional interleaver). The HP and LP transport streams are respectively set at 544 kbps (base layer) and 1,088 kbps (enhancement layer). Table 1 shows the experimental condition, and Fig. 5 shows a basic configuration of the AT-DMB system, where the AT-DMB media encoder includes the proposed algorithm and the AT-DMB modulator has the function of hierarchical modulation. Specifically, Fig. 6 shows an AT-DMB media player

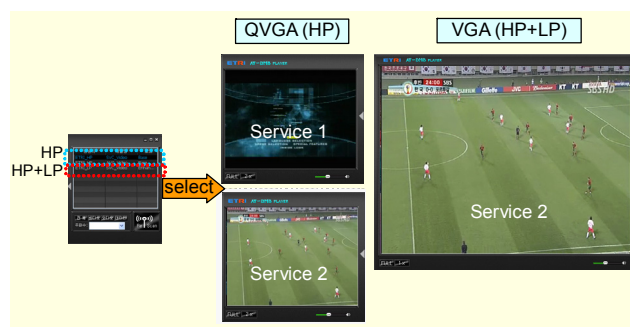

Fig. 6. Implemented scalable video service in the player.

developed to decode two received transport streams on the software platform. As shown in the figure, this player is experimentally capable of decoding three services: two video services of basic quality (QVGA) and one video service of high quality (VGA). Further, it is assured that any conventional T-DMB receiver can provide basic services by receiving only the HP transport stream, which confirms backward compatibility. Our simulation result investigating the SNR required for the condition of BER  $10^{-4}$  (Rayleigh fixed) shows that the HP signal requires 2.3 dB to 4.8 dB more than the existing T-DMB signal and that the LP signal requires 1 dB to 5.1 dB more than the HP signal, being dependent on the modulation parameter ( $\alpha$  value).

#### V. Conclusion

We have described a newly developed advanced T-DMB system and verified the proposed algorithm under a laboratory environment. With the help of proposed system and algorithm, it is possible to provide various solutions with high-quality media services or various data services. The performance of AT-DMB is planned to be investigated in a real situation through a field test at the beginning of 2009.

#### References

- [1] S. Cho et al., "System and Services of Terrestrial Digital Multimedia Broadcasting (T-DMB)," *IEEE Trans. Broadcasting*, vol. 53, no. 1, pp. 171-177, Mar. 2007.
- [2] G. Lee et al., "A Novel Method for Inserting an MPEG-TS into Ensemble in a DMB transmission system," *ETRI Journal*, vol. 26, no. 6, pp. 653-656, Dec. 2004.
- [3] T. Wiegand et al., Joint Draft 11 of SVC Amendment, Joint Video Team, Doc. JVT-X201, July 2007.
- [4] ISO/IEC 23003-1, *Information Technology- MPEG Audio Technologies - Part 1: MPEG Surround*, Feb. 2007.
- [5] K.-D. Seo et al., "Efficient Media Synchronization Mechanism for SVC Video Transport over IP Networks," *ETRI Journal*, vol.30, no.3, June 2008, pp.441-450.