

Design of a Cost-Effective Hybrid-Type PBEx Providing a High Power Budget in an Asymmetric 10G-EPON

Kwangok Kim, Sangsoo Lee, Jonghyun Lee, and Younseon Jang

This paper proposes a cost-effective hybrid-type power budget extender (PBEx) that can provide a high power budget of over 45 dB in an asymmetric 10-Gb/s Ethernet passive optical network (10/1G-EPON). The hybrid-type 10/1G-EPON PBEx comprises a central office terminal (COT) and remote terminal (RT) module supporting four channels and uses a coarse wavelength division multiplexing (CWDM) technology between the COT and RT for a reduction of fiber cost and efficient access network design. The proposed 10/1G-EPON PBEx can provide over a 40-km reach and 128-way split per CWDM wavelength with no modification of a legacy 10/1G-EPON system and can satisfy the error-free service in 10^{10} packet transmission.

Keywords: 10-Gb/s EPON, long-reach EPON, CWDM/EPON, hybrid PON, EPON PBEx, reach extender.

I. Introduction

The 10-Gb/s Ethernet passive optical network (10G-EPON) is an attractive access technology for providing next-generation ultra-broadband services to subscribers. The current 1-Gb/s EPON (1G-EPON) is being extensively utilized as an optical access network in Asian nations, including Japan, South Korea, and China. Recently, a 10G-EPON has been standardized as a next-generation technology to satisfy the increase in user traffic and the demand for various high-definition multimedia services [1].

The current 10G-EPON defines three power budget classes, that is, PR(X)10, PR(X)20, and PR(X)30, of a symmetric rate or asymmetric rate for compatibility with a legacy 1G-EPON. These power budgets support a channel insertion loss of 20 dB, 24 dB, and 29 dB, respectively. Therefore, the 10G-EPON was designed to support the nominal distance of 20 km and the split ratio of 1:32 [2].

However, many network operators require a high power budget to support a high split ratio of more than 1:64 at 40 km and want to combine an optical access network with a metro network by consolidating their central offices (COs). This can provide significant cost savings by reducing the amount of electronic equipment and real estate required at a local exchange. Moreover, it can support broadband service to small towns, suburbs, and rural areas. In addition, service providers hope to address the following business requirements: leveraging EPON architecture in rural areas, increasing subscriber density in their COs, decreasing the connection cost per subscriber, and serving more people at a larger distance

Manuscript received Apr. 19, 2012; revised May 30, 2012, accepted June 15, 2012.

This research was supported by the KCC (Korea Communications Commission), Korea, under R&D program supervised by the KCA (Korea Communications Agency) (KCA-10913-05002).

Kwangok Kim (phone: +82 42 860 1686, kwangok@etri.re.kr), Sangsoo Lee (soolee@etri.re.kr), and Jonghyun Lee (jlee@etri.re.kr) are with the Advanced Communications Research Laboratory, ETRI, Daejeon, Rep. of Korea.

Younseon Jang (jangys@cnu.ac.kr) is with the Department of Electronics Engineering, Chungnam National University, Daejeon, Rep. of Korea.
<http://dx.doi.org/10.4218/etrij.12.1812.0040>

from the COs [3]-[5].

To solve these challenges, we suggest a cost-effective hybrid-type optical-electrical-optical (OEO)-based power budget extender (PBEx) solution providing a long-reach transmission, higher split ratios, and high-volume link capacity to EPON service providers.

Section II reviews the related works, while section III describes the detailed structure and design scheme of the proposed hybrid-type asynchronous 10G-EPON PBEx. Section IV shows the experiment results proving the effectiveness of our method and provides an analysis of its performance. Finally, section V provides some concluding remarks.

II. Related Work

The 10G-EPON specification was standardized by the IEEE 802.3 Working Group in 2009 and supports two configuration modes: symmetric mode, operating at 10 Gb/s in both directions (10/10G-EPON), and asymmetric mode, operating at 10 Gb/s in the downstream direction and at 1 Gb/s in the upstream direction (10/1G-EPON). Additionally, to reduce the cost of laying fibers and equipment, 1G-EPON and 10G-EPON systems use the same outside plant [2], [6].

10/10G-EPON is mainly considered in the multiple dwelling unit market, and 10/1G-EPON is considered in the single family unit market as a cost-effective next-generation solution, as its upstream transmission is identical to that of 1G-EPON, and its downstream transmission relies on the maturity of 10-Gb/s Ethernet devices.

The IEEE 802.3 Working Group authorized the creation of a new project, P802.3bk, focusing on standardizing new physical medium dependent (PMD) classes (that is, PR(X)40 and PR(X)50) as a passive solution and a power budget extender as an active in-field optional solution. The IEEE 802.3 Extended EPON Study Group is focusing mainly on the PR(X)40 PMD

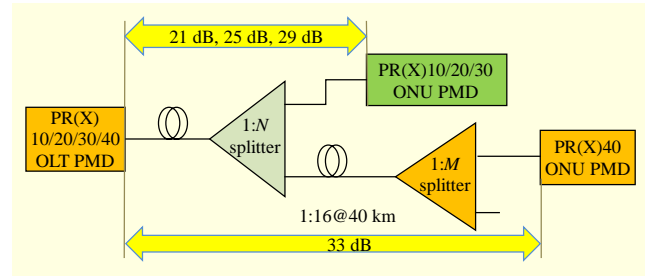

Fig. 1. 10G-EPON link structure suggested by IEEE 802.3 extended EPON study group [2], [3].

definition, as many operators would prefer a completely passive solution [7]. Some markets require a high split ratio of over 1:64 for a 40-km reach through a high power budget of 33 dB [8].

Figure 1 shows the 10G-EPON link structure suggested by the IEEE 802.3 Extended EPON Study Group. A 10G-EPON system supporting a PR(X)40 link budget can extend the nominal distance of 40 km in a 1:16 split ratio without a PBEx in the remote node, as shown in Fig. 1 [9]. The current PR(X)40 PMD is not commercialized yet, and its price is expected to be about 1.2 times the price of the PR(X)30 [10].

Therefore, to support a physical distance of over 40 km and a greater than 1:64 split ratio under worst-case optical distribution network (ODN) design scenarios without any problems, a cost-efficient 10/1G-EPON PBEx solution is required. Although it uses an active device in the remote node, this solution is acceptable to many network operators [4].

III. Proposed Hybrid-Type OEO-Based 10/1G-EPON PBEx

Figure 2 illustrates the 10/1G-EPON link structure including the proposed hybrid-type OEO-based PBEx. The proposed PBEx consists of a 10/1G-EPON CO terminal (COT) and a 10/1G-EPON remote terminal (RT). A 10/1G-EPON COT

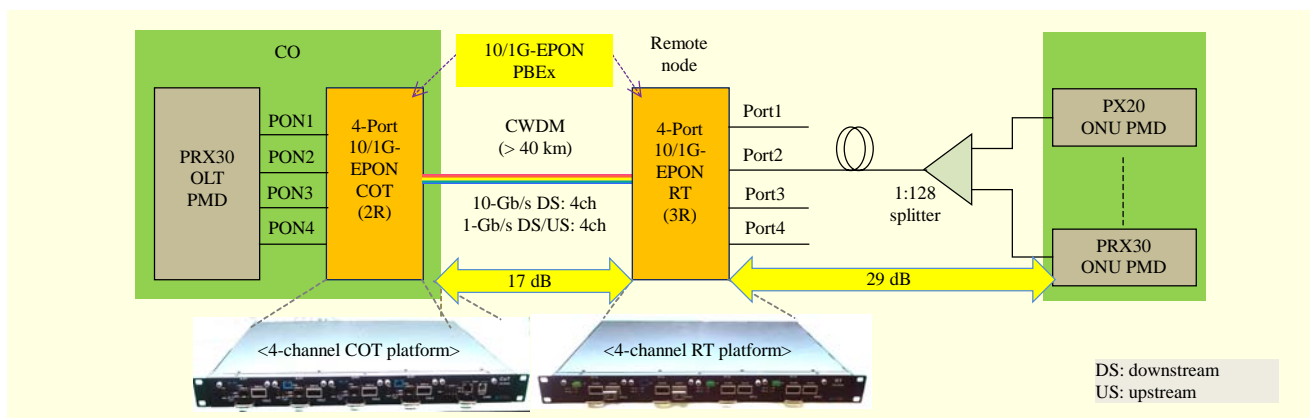

Fig. 2. 10/1G-EPON link structure using proposed hybrid-type PBEx.

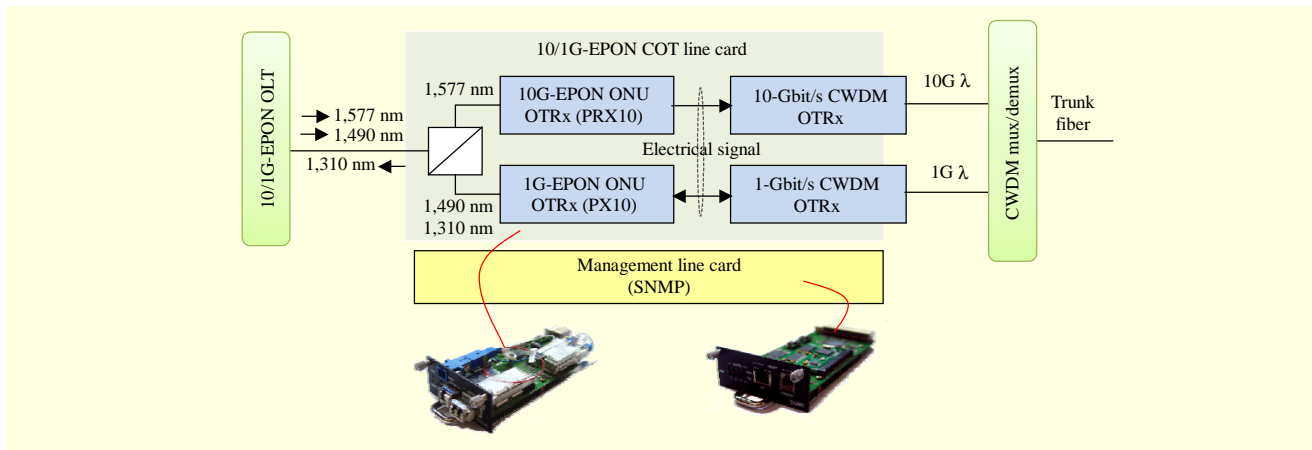

Fig. 3. Internal architecture of 10/1G-EPON COT line cards.

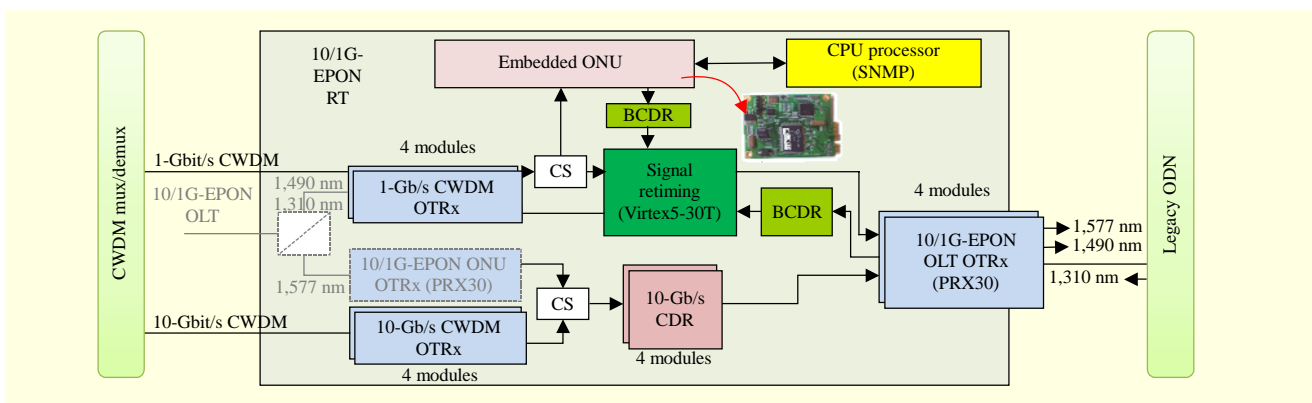

Fig. 4. Internal architecture of 10/1G-EPON RT.

mainly provides a wavelength conversion based on a 2R-based signal regeneration between a legacy 10/1G-EPON optical line terminal (OLT) and coarse wavelength division multiplexing (CWDM) at the same local site. On the other hand, the 10/1G-EPON RT mainly provides wavelength conversion and upstream burst-mode-to-continuous-mode (BM-to-CM) conversion through a 3R-based signal regeneration function between CWDM and legacy EPON optical network units (ONUs).

In the feeder section, the CWDM uses four-channel 10-Gb/s wavelengths for downstream only and four-bidirectional-channel 1-Gb/s wavelengths for downstream and upstream. When an optical fiber loss is 0.4 dB/km, a legacy 10/1G-EPON can easily support a high split ratio of 1:128 at over 50 km from a CO to end users using a hybrid-type 10/1G-EPON PBEx. This makes a flexible access network configuration possible for operators.

For a cost-effective solution, the 10/1G-EPON COT is designed for a four-channel structure, as shown in Fig. 2. The line card of the 10/1G-EPON COT connects with the PON port of the legacy 10/1G-EPON OLT and provides 10-Gb/s

and 1-Gb/s transmission rates at the downstream path and a 1-Gb/s transmission rate at the upstream path, as shown in Fig. 3. That is, the 10/1G-EPON COT can support a total transmission rate of 44 Gb/s in the downstream and 4 Gb/s in the upstream.

The line card of the 10/1G-EPON COT comprises a three-port edge WDM filter to connect with a 10/1G-EPON OLT, a 1G-EPON PX10 ONU PMD to transmit a 1-Gb/s optical signal, a 10G-EPON PRX10 ONU PMD to transmit downstream only 10-Gb/s optical signals, and 1-Gb/s and 10-Gb/s CWDM optical modules to transmit a CWDM signal to the RT.

A three-port edge WDM filter divides 10-Gb/s (1,577 nm) and 1-Gb/s (1,490 nm) optical signals from an input EPON signal. These optical signals are transmitted to each EPON ONU PMD and converted into electrical signals. These electrical signals are transmitted to each CWDM optical module through a level termination, and a wavelength conversion is then performed. In contrast, at the upstream path, an optical signal received from a 10/1G-EPON RT to a 1-Gb/s CWDM optical module is converted into the EPON

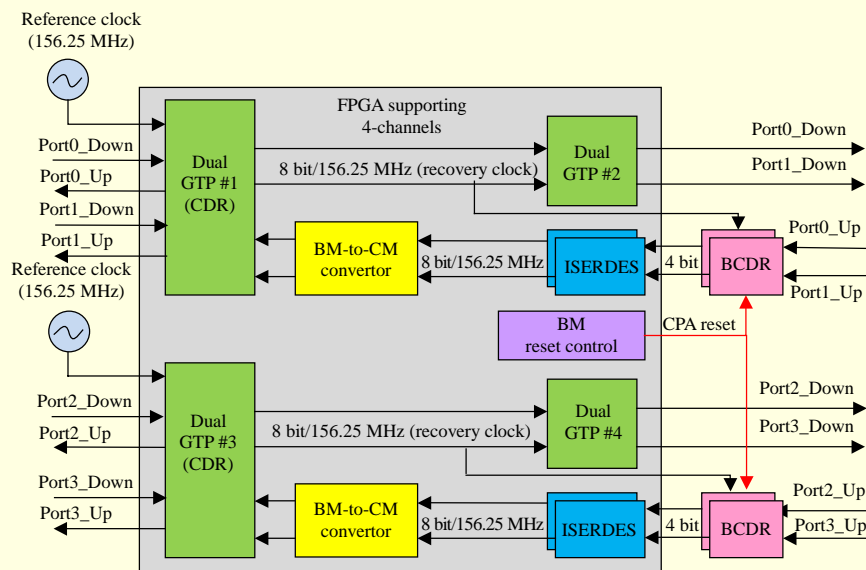

Fig. 5. Internal structure of FPGA for 3R-based signal regeneration [10].

wavelength (1,310 nm) through a 1G-EPON ONU optical module. The management line card gathers the status of the installed optical modules per line card based on the SFF-8472 and performs remote management using a simple network management protocol (SNMP).

Figure 4 shows the internal architecture of the developed 10/1G-EPON RT. The 10/1G-EPON RT is composed of 1-Gb/s and 10-Gb/s CWDM optical modules for receiving a CWDM signal, a low-cost field programmable gate array (FPGA) for signal retiming of a 1-Gb/s downstream signal, an embedded ONU for SNMP packet transmission to the 10/1G-EPON OLT, a CPU processor providing SNMP for remote management, a BM clock and data recovery (BCDR) device for retiming of the BM upstream signal, a crosspoint switch (CS) for electrical signal division, and a PRX30 OLT PMD for interconnection with a legacy ODN.

The 10/1G-EPON RT provides an upstream BM-to-CM signal conversion to support CWDM multiplexing in the feeder section. It also converts an optical signal into an electrical signal in the optical domain and then retimes these signals through an FPGA and 10-Gb/s clock and data recovery (CDR) in the electrical domain. These retimed signals are then retransmitted to the optical domain using a 10/1G-EPON OLT module. In contrast, the 1-Gb/s signal regeneration in the upstream is performed using a commercialized BCDR device and then converts the retimed upstream BM signal into a CM signal through the FPGA. The 10/1G-EPON RT is designed to have a four-channel structure and a Virtex-5 FPGA (XC5VLX-30T) to keep design costs and power consumption low.

To provide remote management of the 10/1G-EPON RT, an

embedded ONU is activated using a 10/1G-EPON OLT and provided as a compact-type commercialized 1-Gb/s EPON ONU media access control, as shown in Fig. 4. An embedded ONU receives a downstream signal through a CS device and transmits an upstream signal to the 10/1G-EPON OLT through a BCDR device and the FPGA.

The CPU processor gathers and manages the status of the installed optical modules and FPGA. It also communicates with a 10/1G-EPON OLT using an SNMP through an embedded ONU without an external optical tap (for example, an optical splitter), which is unlikely to have been used in previous methods. Additionally, the 10/1G-EPON RT can be used as a reach extender of a 10/1G-EPON without a COT by replacing a CWDM with EPON ONU optical modules.

Figure 5 illustrates the internal architecture within the FPGA for signal retiming. In the downstream direction, the FPGA provides 3R signal regeneration using a recovery clock extracted from the CDR, which is included in the dual gigabit transfer protocol (GTP). The dual GTP extracts a 156.25-MHz recovery clock and 8-bit data using 1.25-Gb/s input serial data and a 156.25-MHz reference clock. This recovery clock is then used as a reference clock, which is necessary for an external BCDR device.

On the other hand, in the upstream direction, the 10/1G-EPON RT performs a signal recovery using a BCDR device and transmits this recovered signal to an input serializer/deserializer (ISERDES). In addition, a BM reset signal for a BCDR device is generated by a loss of signal of a 10/1G-EPON OLT optical module.

The BCDR device aligns with the input data within the

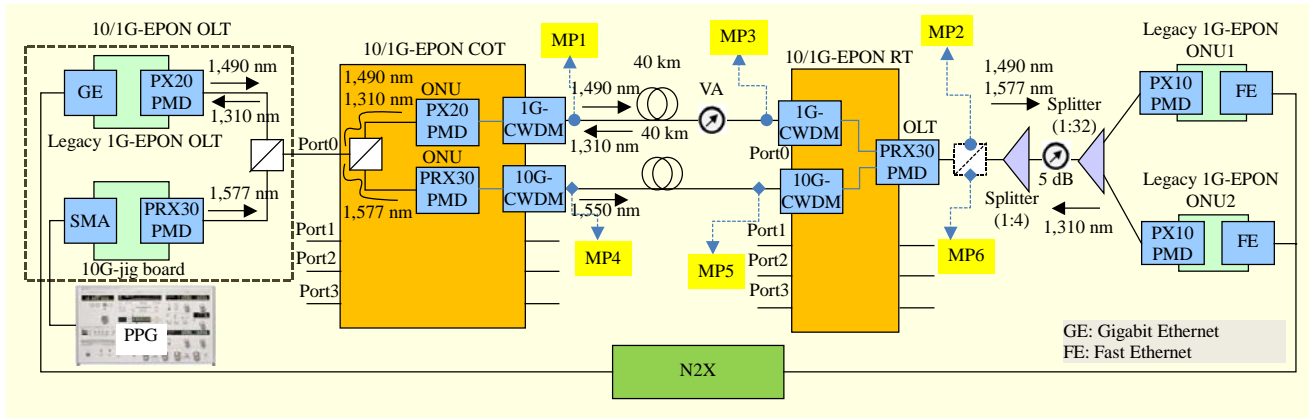

Fig. 6. Experimental setup for performance measurement of proposed hybrid-type 10/1G-EPON PBEx.

12-bit acquisition time and changes a 1-bit serial signal into a 4-bit parallel signal to provide a lower clock speed for the data transmission to the FPGA. The BM-to-CM convertor is used at the remote node to convert the burst upstream signal into a conventional continuous signal through a bit pattern (for example, h'55) signal inserted between the bursts. This bit pattern is configured by remote management [11].

The 10/1G-EPON PBEx proposed in this paper has a cost-efficient design and its power consumption is low owing to a quad-port structure using a single FPGA and generalized low-cost EPON optical modules with no modification of a legacy 10/1G-EPON system.

IV. Experimental Setup and Results

1. Experimental Setup

The experimental setup for a performance measurement of the proposed hybrid-type 10/1G-EPON PBEx is shown in Fig. 6. As there are no commercialized 10/1G-EPON systems at present in South Korea, we use the commercialized 1G-EPON system and a 10G-jig board. The legacy 1G-EPON OLT/ONUs generate downstream and upstream data signals with a line rate of 1.25 Gb/s, while the 10G-jig board transmits only a downstream optical signal with a line rate of 10.3125 Gb/s using an external pulse pattern generator (PPG) and a PRX30 OLT PMD.

We use a 1.25-Gb/s EPON ONU transceiver compliant with a PX20 [6], a 10.3125-Gb/s EPON ONU transceiver compliant with a PRX30 [2], a 1.25-Gb/s bidirectional small form-factor pluggable CWDM transceiver compliant with a BX10, and a 10-Gb/s CWDM transceiver compliant with a 10GBASE-E at a 10/1G-EPON COT. The EPON transceivers are interconnected with a 10/1G-EPON OLT, and the CWDM transceivers generate the CWDM wavelengths. We also apply the same CWDM transceivers to a 10/1G-EPON RT to connect with a 10/1G-

EPON COT and use a 10-Gb/s EPON OLT transceiver compliant with a PRX30 to accommodate the existing ODN.

In the link configuration for a 1.25-Gb/s data transmission at the downstream and upstream directions, we use a single legacy 1G-EPON OLT and two 1G-EPON ONUs and connect the trunk fiber using a 40-km single-mode fiber (SMF) including a variable attenuator (VA) between the 10/1G-EPON COT and the RT. In addition, we configure a 1:4 optical splitter, a fixed 5-dB attenuator, and a 1:32 optical splitter as the drop fiber between the 10/1G-EPON RT and 1G-EPON ONUs. In the link configuration for a 10-Gb/s data transmission in only the downstream direction, we also connect the trunk fiber using a 40-km SMF without a CWDM mux/demux.

The 1.25 Gb/s (that is, 1,490 nm) and 10.3125 Gb/s (that is, 1,577 nm) optical wavelengths outputted at a 1G-EPON OLT and 10G-jig board are merged using a three-port edge WDM filter and then separated again into 1.25-Gb/s and 10.3125-Gb/s optical wavelengths using a three-port edge WDM filter within the 10/1G-EPON COT. The 10/1G-EPON COT changes EPON downstream wavelengths into CWDM wavelengths (that is, 1,490 nm and 1,550 nm), and these wavelengths are then reconverted through 40-km SMF into EPON downstream wavelengths using a 10/1G-EPON RT. The wavelength data is then transmitted into EPON ONUs through two optical splitters. On the other hand, 1.25-Gb/s upstream BM optical signals (that is, 1,310 nm) outputted at each EPON ONU are changed into a 1.25-Gb/s CM CWDM wavelength (that is, 1,310 nm), which is then reconverted into a CM EPON upstream wavelength using a 10/1G-EPON COT. In this experimental setup, the insertion losses in the trunk and drop fibers are measured to be about -11.6 dB and -28.4 dB, respectively.

2. Optical Eye Diagram Measurement and Analysis

Figure 7 shows optical eye diagrams of each measurement

point (MP) in the experimental setup link for the proposed hybrid-type 10/1G-EPON COT and RT. The 10/1G-EPON COT simply provides a wavelength conversion based on a 2R signal generation, but the 10/1G-EPON RT performs a wavelength conversion and signal retiming using a recovery clock extracted through a 1.25-Gb/s CDR within the FPGA and a 10-Gb/s CDR device, and this retimed signal is again recovered by the 1G-EPON ONUs.

In a 1.25-Gb/s transmission path, the downstream CWDM optical wavelength measured at MP1 is received by a 1G-CWDM transceiver installed within a 10/1G-EPON RT using a 40-km SMF. In an optical eye diagram measured at MP2 and MP3, as shown in Figure 7, we can see a clear eye

pattern satisfying the optical eye mask adapted from the IEEE Gigabit Ethernet standard through 3R signal regeneration. In a 10.3125-Gb/s transmission path, although an optical eye diagram (MP5) passed by a 40-km SMF shows that a slight jitter is added to the 10-Gb/s CWDM downstream optical eye diagram (MP4), we can confirm that MP5 shows the results of a clear eye pattern satisfying the standard optical eye mask. We can also confirm that the output optical signal measured at MP6 satisfies the optical eye mask adapted from the IEEE 10.3125 Gb/s Ethernet standard by the 3R signal regeneration, as shown in Fig. 7. This means it is possible to support a transmission reach of over 40 km per CWDM wavelength at the feeder section through our proposed hybrid-type 10/1G-EPON PBEx without a new PMD definition.

Figure 8 shows the experimental setup and optical eye diagrams measured in the use of only a 10/1G-EPON RT as an EPON extender without a 10/1G-EPON COT. In optical eye diagrams measured at MP1, MP2, and MP3, we can confirm that a 1.25-Gb/s transmission path can support a transmission reach of 40 km at the feeder section and meet the standard optical eye mask of a Gigabit Ethernet. However, in a 10.3125-Gb/s path, we can confirm that the current commercialized 10/1G-EPON PRX30 PMD supports a transmission distance of 20 km based on the results of the transmission dispersion, as shown in MP5. However, we can show that the output optical signal measured at MP6 satisfies the optical eye mask adapted from the IEEE 10.3125-Gb/s Ethernet standard using 3R signal regeneration.

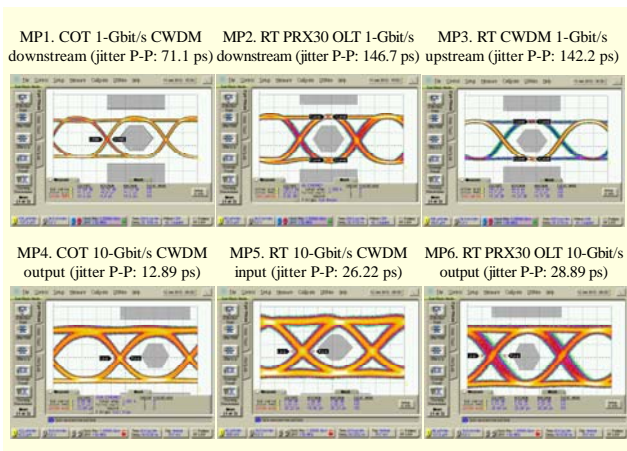

Fig. 7. Optical eye diagrams measured at each MP.

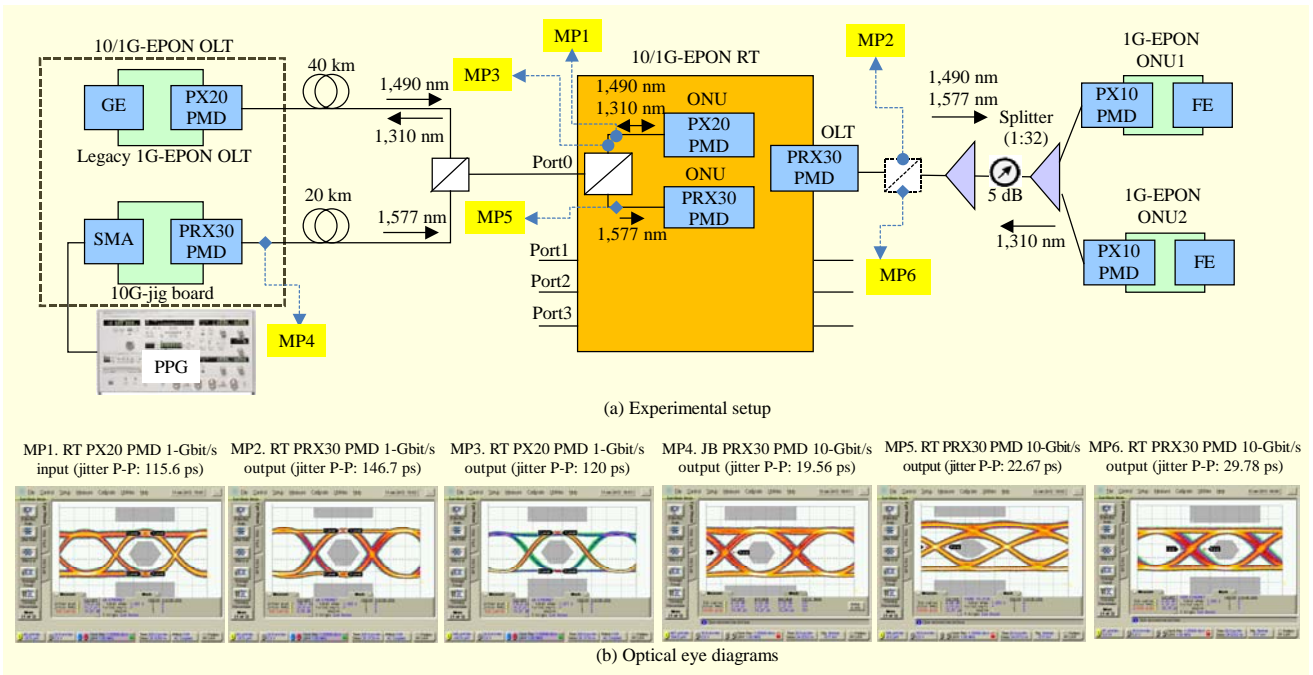

Fig. 8. Experimental setup and results at 10/1G-EPON RT.

3. Packet Transmission Results and Performance Analysis

To verify the transmission performance of the proposed 10/1G-EPON PBEx, we measure the packet error using Ethernet packets with random lengths ranging from 64 bytes to 1,518 bytes using a commercially available router tester (Agilent N2X). We transmit 10^{10} packets for the packet loss rate (PLR) test per MP.

Figure 9 shows the packet error rate (PER) results measured at the existing extended 1G-EPON link according to the VA value through a hybrid-type 10/1G-EPON PBEx. In this experiment, as shown in Fig. 9(a), the proposed hybrid-type 10/1G-EPON PBEx satisfies the error-free service during a 10^{10} packet transmission up to a link budget of 45 dB when accounting for a link budget of 28 dB at an ODN. This means that a 10/1G-EPON system using the proposed 10/1G-

EPON PBEx can support a physical distance of over 40 km in a 1:128 split ratio per CWDM wavelength according to the CWDM transceiver. Figure 9(b) also shows the PLR results using a 10/1G-EPON RT without a 10/1G-EPON COT. From these PLR results, we can achieve the error-free service during a 10^{10} packet transmission up to a total link budget of 56 dB. Because a 1-Gb/s EPON OLT and ONU transceivers use an avalanche photodiode and a positive intrinsic negative-photodetector, respectively, we can show that the upstream link budget increases by about 3 dB more than that of the downstream. That is, a 10/1G-EPON system using the proposed 10/1G-EPON RT is able to provide a physical distance of 80 km for a 1:128 split ratio, when we take into account a budget loss of 0.4 dB/km in an optical fiber.

Figure 10 shows the results of a packet transmission test of a legacy 1G-EPON system using our proposed 10/1G-EPON PBEx. Over a 66-hour period, we transmit a packet load of 19% from a 1G-EPON OLT to each 1G-EPON ONU and assign a packet load of 98% at each 1G-EPON ONU to measure the upstream PERs, as a commercialized 1G-EPON ONU supports only a Fast Ethernet port. From Fig. 8, we can confirm the possibility of 10^{10} packet loss-free service in the downstream and upstream paths.

Therefore, using general CWDM technology and the proposed 10/1G-EPON extender box, we can design a cost-effective hybrid-type long-distance 10/1G-EPON solution that supports over a 40-km reach and accommodates a maximum of 1,024 subscribers with a link capacity of 44 Gb/s on a single feeder fiber.

4. Technical Comparisons

Table 1 shows the results of three technical comparisons of a 10/1G-EPON using the proposed hybrid-type 10/1G-EPON PBEx, a 10/1G-EPON standardized by IEEE802.3av-2009, and the extended 10/1G-EPON suggested by the IEEE P802.3bk Working Group to account for a 40-km transmission reach [2], [5].

Although the active device is used in the remote node, the 10/1G-EPON using the proposed PBEx can support up to four times the split ratios at the same physical distance through a power budget of 45 dB, as shown in Table 1 [5], [8]. Although the guaranteed bandwidth per user is lower than that achieved using other technologies, a 100-Mb/s bandwidth is suitable to provide downstream-intensive application services in the near future.

In addition, a 10/1G-EPON using the proposed PBEx can only apply the CM WDM technology in the trunk section through an OEO conversion. If X denotes the cost of PRX30 OLT/ONU PMD, the 10/1G-EPON PBEx can be added at

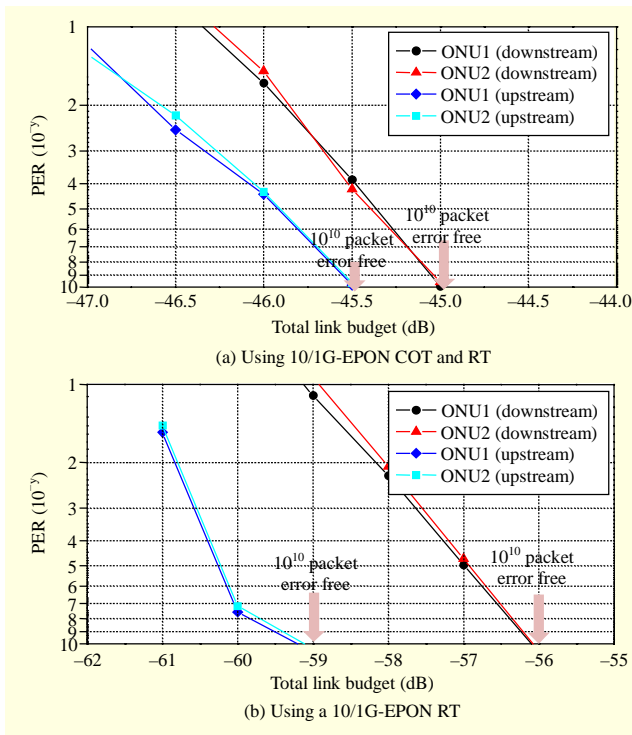

Fig. 9. PER results of 1.25-Gb/s EPON link.

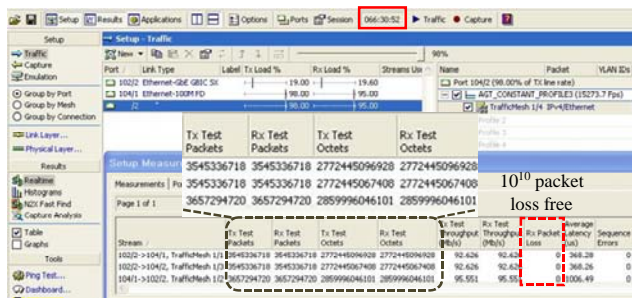

Fig. 10. Result of a long-term PER test.

Table 1. Example for technical comparison in condition of 40-km transmission reach.

Items	IEEE 802.3av 10/1G-EPON	IEEE P802.3bk 10/1G-EPON	ETRI hybrid-type 10/1G-EPON
Power budget	29 dB (PRX30)	33 dB (PRX40)	45 dB ¹
Split ratio	1:8	1:16	1:128
Downstream bandwidth per user	1,250 Mb/s	600 Mb/s	100 Mb/s
Link	All passive	All passive	Partial active
Upstream mode	BM	BM	CM
Using WDM in trunk fiber	No	No	Yes
Equipment per user	PRX30 1 OLT/ 8 ONU PMD ²	New PRX40 1 OLT/ 16 ONU PMD ³	PRX30 1 OLT/ 128 ONU PMD, 10/1G COT ⁴ , 10/1G RT ⁵
Expected cost	200%	300%	2,030% ⁶
Cost per user	High (25%)	Middle (18.7%)	Low (15.8%)
Cost of trunk fiber	1	1	1/8 ⁷

- Budget is calculated by using 40-km CWDM optical module and PRX30 PMD.
- ONU PMD is about 1/8 the cost of OLT PMD [12].
- Korea's operators account for additional cost of about 30% compared to PRX30 PMD [13].
- 10/1G COT includes PX10 ONU PMD, PRX10 ONU PMD, 10-Gb/s CWDM, and 1-Gb/s CWDM transceiver; cost is estimated to be 80% more per port compared to that of PRX30 PMD.
- 10/1G RT includes 10-Gb/s CWDM, 1-Gb/s CWDM, and PRX30 OLT PMD; cost is estimated to be about 250% more per port compared to that of PRX30 PMD.
- Expected cost = OLT PMD × {ONU PMD# × (OLT PMD cost/8)} + COT/RT cost per port.
- Assumed that CWDM has been applied to feeder section.

about 3.3X per port, as shown in Table 1. Therefore, with the exception of bandwidth per user, a 10/1G-EPON system using the proposed 10/1G-EPON PBEx can provide greater efficiency with respect to power budget, user accommodation, cost per subscriber, and long-distance trunk fiber costs.

V. Conclusion

We proposed and experimentally demonstrated an efficient hybrid-type OEO-based 10/1G-EPON extender box based on a quad-port architecture to overcome the physical limitations of a legacy 10/1G-EPON system. We also confirmed that our proposed 10/1G-EPON PBEx can achieve a high power budget of 45 dB through 3R signal regeneration using an existing 10/1G-EPON PMD and can support a cost-effective

long-distance 10/1G-EPON system through a WDM solution at the feeder section.

Our experiment results verified that the proposed 10/1G-EPON PBEx can provide a distance of more than 40 km with a 1:128 split ratio under the condition of loss-free service, which many service providers desire. If a 10/1G-EPON RT is used as a 10/1G-EPON extender box, it can provide a maximum link budget of 56 dB and allow a reach of 80 km in a 1:128 split ratio with no modification of the legacy 10/1G-EPON standard.

In addition, the proposed 10/1G-EPON PBEx can be applied as the near-term next-generation PON solution, and an energy-efficient access network can be configured by eliminating the majority of the COs.

References

- C. Chen, Z. Chair, and B. Velmurugan, "10G EPON: Next Generation Ethernet Passive Optical Networks," *Proc. OFC/NFOEC*, Mar. 2009, pp. 1-3.
- IEEE Std. 802.3av, "Carrier Sense Multiple Access with Collision Detection (CSMA/CD) Access Method and Physical Layer Specification, Amendment 1: Physical Layer Specifications and Management Parameters for 10 Gb/s Passive Optical Networks," 2009.
- M. Hajduczenia, "Call For Interest Consensus Building Meeting: Extended EPON PMDs," IEEE 802.3 Working Group, consensus building meeting, San Francisco, CA, USA, July 19, 2011. Available: http://grouper.ieee.org/groups/802/3/EXTND_EPON/public/1107/index.html
- E. Mallette, "Five Criteria Board Market Potential," IEEE 802.3 Extended EPON Study Group, 802.3 plenary meeting, Atlanta, GA, USA, November 2011. Available: http://grouper.ieee.org/groups/802/3/EXTND_EPON/public/1107/index.html
- M. Hajduczenia, "Project Objectives...How Far, How Long...," IEEE 802.3 Extended EPON Study Group, 802.3 plenary meeting, Atlanta, GA, USA, Nov. 2011. Available: http://grouper.ieee.org/groups/802/3/EXTND_EPON/public/1107/index.html
- IEEE Std. 802.3ah, "Carrier Sense Multiple Access with Collision Detection (CSMA/CD) Access Method and Physical Layer Specifications," 2008.
- FTTH Council, "The Advantages of Fiber," *Fiber to the Home*, 3rd ed., Spring 2009, pp. Sec2:1-32.
- B. Wang, J. Xu, and Z. Fu, "Proposal for Extended EPON PMD," IEEE 802.3 Extended EPON Study Group, 802.3 plenary meeting, Atlanta, GA, USA, Nov. 2011. Available: http://grouper.ieee.org/groups/802/3/EXTND_EPON/public/1107/index.html
- D. Piehler, "Extending EPON Link Budget without New PMD Definitions," IEEE 802.3 Extended EPON Study Group, 802.3 plenary meeting, Atlanta, GA, USA, Nov. 2011. Available:

http://grouper.ieee.org/groups/802/3/EXTND_EPON/public/1107/index.html

- [10] K.O Kim et al., "Low-Cost, Low-Power, High-Capacity 3R OEO-Type Reach Extender for a Long-Reach TDMA-PON," *ETRI J.*, vol. 34, no. 3, June 2012, pp. 352-360.
- [11] ITU-T Recommendation G.984.6 Amendment 1, "Gigabit-Capable Passive Optical Networks (GPON): Reach Extension Amendment 1: Wavelength-Converting, Continuous Mode, and 1:N-Protected Range Extenders," Nov. 2009.
- [12] <http://www.sourcephotonics.com>
- [13] D. Li, "Cost Comparison of the 10G-EPON PMDs," IEEE 802.3 Extended EPON Study Group, Nov. 2011. Available: http://grouper.ieee.org/groups/802/3/EXTND_EPON/public/1111/index.html



Kwangok Kim received his BS in information and communication engineering from Chosun University, Gwangju, Rep. of Korea, in 1999 and his MS in electronics engineering from Chonnam National University, Gwangju, Rep. of Korea, in 2001. Currently, he is a senior researcher at ETRI and a PhD student at

Chungnam National University, both in Daejeon, Rep. of Korea. His research interests include passive optical network technologies, such as TDMA-PON, WDM-PON, and OFDMA-PON.



Sangsoo Lee received his BS and MS in applied physics and his PhD in the area of DWDM transmission technology from Inha University, Incheon, Rep. of Korea, in 1988, 1990, and 2001, respectively. He has conducted research in 2.5-, 10-, and 40-Gbps-based DWDM optical transmission and the ROADM

system. His current research activities are in optical access networks, WDM-PON, and energy efficient network technology. Dr. Lee is the leader of the Optical Access Research Team of ETRI, Daejeon, Rep. of Korea.



Jonghyun Lee received his BS and MS in electronics engineering and his PhD in communication engineering from Sungkyunkwan University, Seoul, Rep. of Korea, in 1981, 1983, and 1993, respectively. In 1983, he joined ETRI, Daejeon, Rep. of Korea.

His current research activities are in optical communication systems and optical Internet technology. Dr. Lee is the head of the Optical Internet Research Department at ETRI.



Younseon Jang received her BS in electronics engineering from Kyungpook National University, Daegu, Rep. of Korea, in 1992 and her MS and PhD in electrical and electronics engineering from the Korea Advanced Institute of Science and Technology (KAIST), Daejeon, Rep. of Korea, in 1994 and 1999, respectively.

From 1999 to 2006, she was a senior member of the research staff at ETRI, Daejeon, Rep. of Korea. In 2006, she joined the faculty of Chungnam National University, Daejeon, Rep. of Korea, where she works as an assistant professor in electronics engineering. Her current research interests include WDM-PON, channel resource management in cognitive radio systems, Positioning, Navigation, and Timing (PNT) data networking, and MAC protocol in underwater acoustic sensor networks. Prof. Jang is a member of IEEE, IEICE, and KICS.