

A Compact C-Band 50 W AlGa_N/Ga_N High-Power MMIC Amplifier for Radar Applications

Jin-Cheol Jeong, Dong-Pil Jang, Byoung-Gon Han, and In-Bok Yom

A C-band 50 W high-power microwave monolithic integrated circuit amplifier for use in a phased-array radar system was designed and fabricated using commercial 0.25 μm AlGa_N/Ga_N technology. This two-stage amplifier can achieve a saturated output power of 50 W with higher than 35% power-added efficiency and 22 dB small-signal gain over a frequency range of 5.5 GHz to 6.2 GHz. With a compact 14.82 mm² chip area, an output power density of 3.2 W/mm² is demonstrated.

Keywords: C-band, microwave monolithic integrated circuit, high power amplifier, Ga_N, saturated output power, power density.

I. Introduction

In active phased-array antenna systems, power-amplifying monolithic microwave integrated circuits (MMICs) are the key components for constructing an individual tile or element within a phased array, and their power efficiency is the key parameter. To achieve better power efficiency, a higher output power of an individual high-power amplifier (HPA) is required to reduce the output combined loss.

Among several implementations, those based on AlGa_N-Ga_N may be the best candidates for high-power and high-efficiency operation owing to a high breakdown and high thermal conductivity [1]. To make a Ga_N-HPA economically attractive, a cost reduction of each chip is essential. The chip cost is mainly determined by the chip size and its power performance, which is represented as the output power density (that is, the saturated output power per die area).

A C-band HPA with a maximum output power of 20 W and an output power density of 1 W/mm² was recently realized by Florian et al. [2] using a united monolithic semiconductor (UMS) 0.25 μm Ga_N. Cree CMPA5585025D provides an attractive performance, a maximum output power of 40 W, and a power density of 2.3 W/mm² [3]. TriQuint also released a packaged HPA—namely, the TGA2576-FL3—with a wideband performance at an output power of 35 W [4].

In this letter, we designed a C-band 50 W HPA with nearly 40% power-added efficiency (PAE) using a commercial 0.25 μm Ga_N technology. Its chip area is only 14.82 mm², and its output power density is as high as 3.2 W/mm². To prove reliability, an IR temperature image measurement is performed based on a previous reported thermal measurement for an X-band 50 W HPA [1]. The junction temperature is measured to be 166.9°C at a base plate temperature of 80°C.

II. Power Amplifier Design

For a 50 W HPA design, a commercial foundry of a Cree 0.25 μm AlGa_N-Ga_N high-electron-mobility transistor (HEMT) with a 100 μm thick silicon carbide substrate [5] was selected. The process provides HEMTs with an 84 V three-terminal breakdown voltage, 4.6 W/mm continuous wave (CW) power output, and 56% drain efficiency at a 3 dB compression from the saturation point.

Figure 1 shows a simplified block diagram for the C-band two-stage 50 W cascaded HPA. The HPA has 1:2 gate periphery ratios for the first stage to provide sufficient power driving. The HPA is composed of a first stage with 6 mm (4 × 6F250) gate width and a second stage with 12 mm (8 × 6F250) gate width.

To make a stabilized HEMT cell, a stability circuit composed

Manuscript received Aug. 27, 2013; revised Oct. 18, 2013; accepted Nov. 5, 2013.

Jin-Cheol Jeong (phone: +82 42 860 6422, jchung@etri.re.kr), Dong-Pil Jang (dpjang@etri.re.kr), and In-Bok Yom (ibyom@etri.re.kr) are with the Broadcasting & Telecommunications Media Research Laboratory, ETRI, Daejeon, Rep. of Korea.

Byoung-Gon Han (bghan@rthic.com) is with the Radar Group, RFHIC Corporation, Suwon, Rep. of Korea.

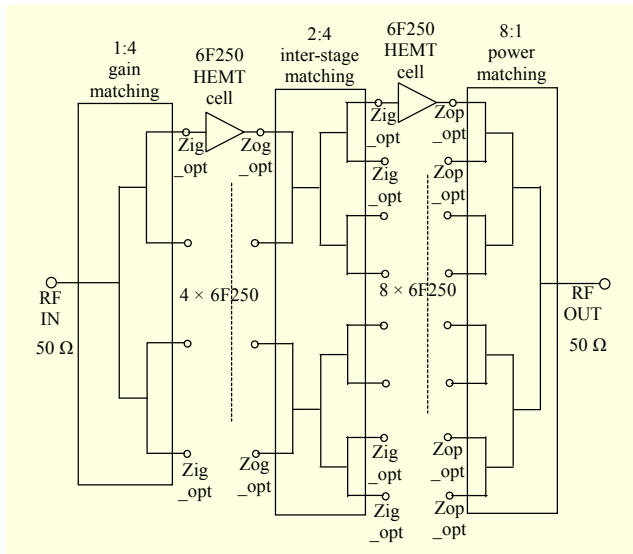

Fig. 1. Functional block diagram of a C-band MMIC HPA.

of a parallel-combined resistor (R1) and capacitor (C1) is connected to an input of the 6F250-HEMT, as shown in Figs. 2(a) and 3. To provide no maximum output power degradation with some gain decrease, the values of the resistors (94 Ω) and capacitor (1.3 pF) were carefully selected. All HEMT cells in Fig. 1. include the stability circuit to provide sufficient stability for the HPA over a wide frequency band.

The MMIC HPA design was performed according to the design procedure of the Ka-band high linear HPA [6]. To improve the power efficiency, the selected quiescent bias point was at class-AB. Figure 2(b) shows the simulation results of the I-V curve for the HEMT cell. The selected bias points are $V_D = 35$ V and $I_D = 100$ mA at the class-AB bias point.

Based on the load/source pull simulation, an output-matching circuit was designed to provide maximum output power while the input and two inter-stage matching circuits give maximum gain.

A first step toward designing an MMIC HPA, is to extract optimum input- and output-impedances for the HEMT cell. In this design, an input impedance (Z_{ig_opt}) for maximum gain, an output impedance for maximum gain (Z_{og_opt}), and a maximum output power (Z_{op_opt}) are required, as shown in Fig. 2(a). Most matching circuits are realized with lumped elements, including capacitors instead of open-stubs with microstrip lines, to achieve a compact chip size. Figure 1 shows the impedance condition for each port. There are three types of matching circuit for the HPA design. First, is the 1:4 input gain matching circuit with an output-port impedance set to Z_{ig_opt} . Second, is the 2:4 inter-stage gain matching circuit with input- and output-port set to Z_{og_opt} and Z_{ig_opt} , respectively. Finally, the 8:1 output power matching circuit has input-port impedance set to Z_{op_opt} . Each matching circuit

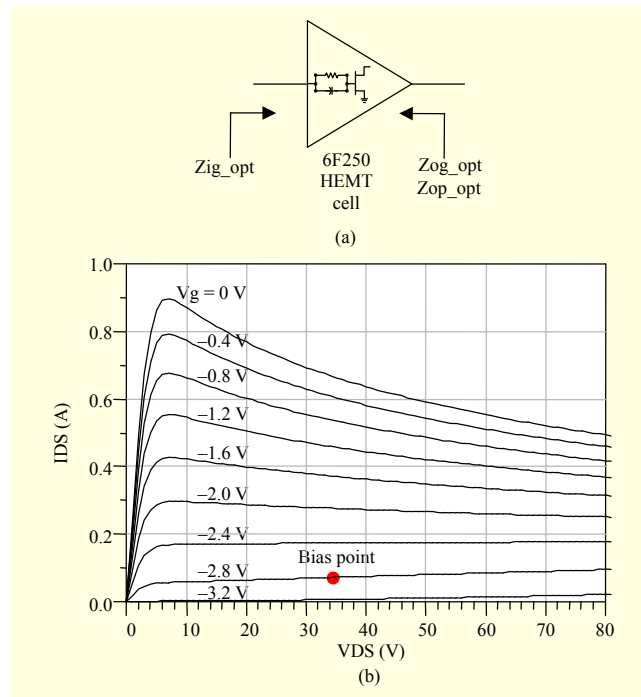

Fig. 2. HEMT cell and its quiescent operation bias point.

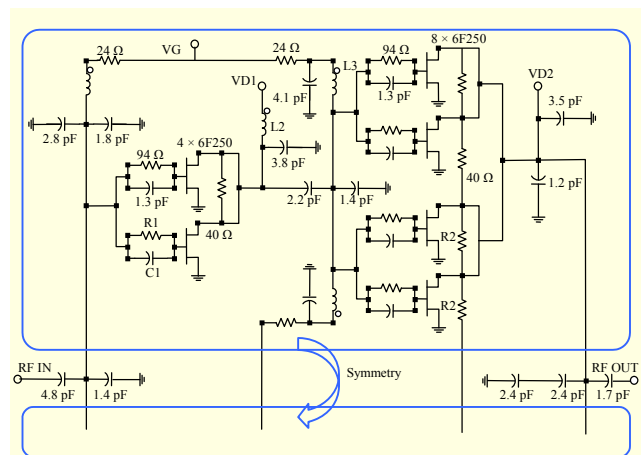

Fig. 3. Detailed circuit diagram of C-band HPA.

was optimized to provide fully low input- and output-return losses over a wide frequency band, considering a compact chip size.

Figure 3 shows a detailed schematic diagram with the component values. To improve the power balancing, 40 Ω resistors (R2) are connected between adjacent parallel HEMT outputs.

III. Measured Results and Comparison

A microphotograph of the fabricated C-band 50 W MMIC HPA is presented in Fig. 4. The chip size is 3.8 mm × 3.9 mm,

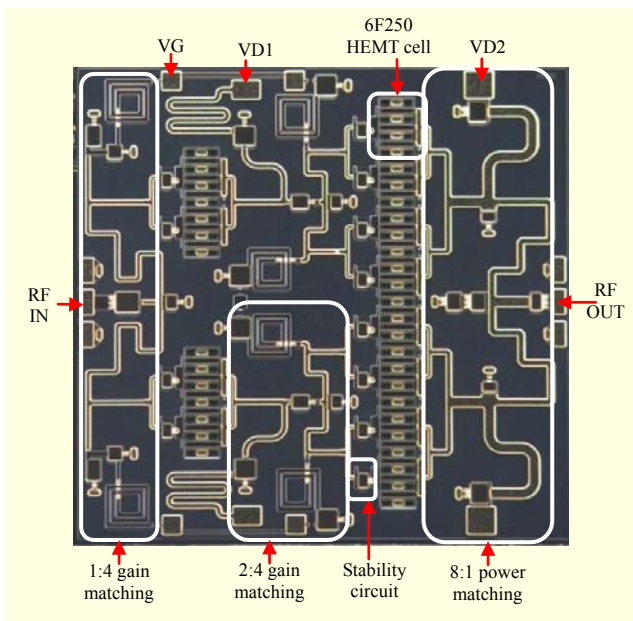

Fig. 4. Microphotograph of fabricated C-band 50 W MMIC HPA. Chip size is 3.8 mm × 3.9 mm.

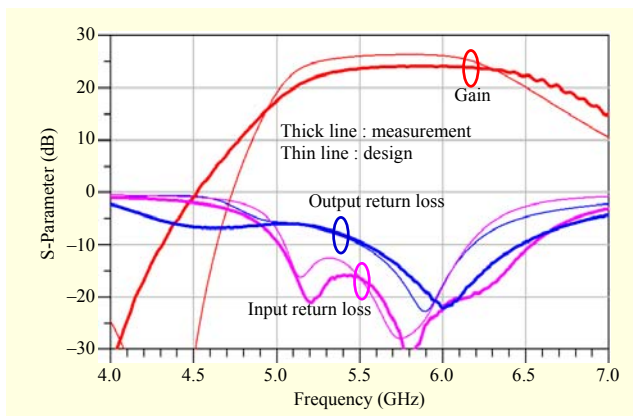

Fig. 5. S-parameter (small-signal gain, input return loss, and output return loss) vs. frequency of C-band HPA.

and its thickness is 0.1 mm.

The S-parameter, which includes a small signal gain, input and output return losses, was measured under the CW condition. The drain voltage (VDS) and the gate voltage (VGS) were set to 35 V and -2.8 V, respectively. The frequency performance of the measured gain is better than the simulation, which is believed to be due to the improved output return loss at the lower frequency. The small signal gain was normally 22 dB, while the input return losses were lower than -15 dB from 5.5 GHz to 6.2 GHz, as shown in Fig. 5.

The gate voltage was pulsed at -2.8 V for a fixed drain bias of 35 V, under the condition of a pulse width of 100 μs and a duty cycle of 10% for the power measurement. Frequency performances for the output power, gain, and PAE are shown

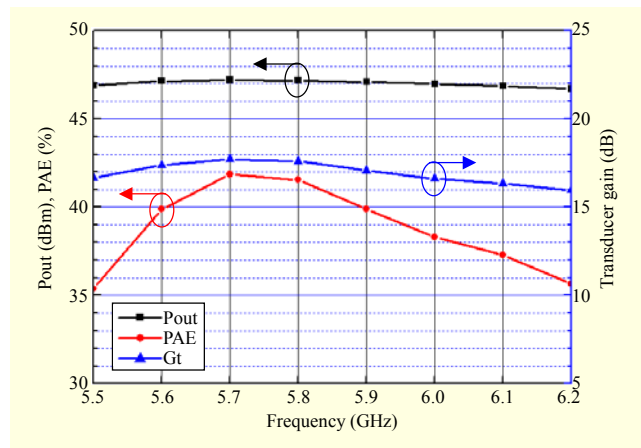

Fig. 6. Measured output power, PAE, and gain of C-band HPA vs. frequency (input power = 30 dBm, VDS = 35 V, pulse width = 100 μs, and duty factor = 10%).

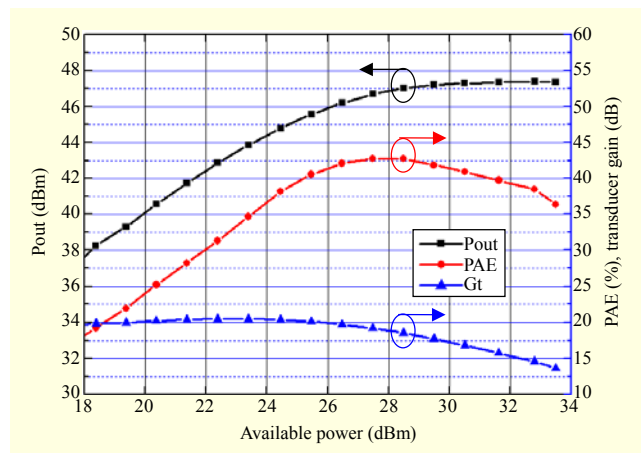

Fig. 7. Measured CW output power, PAE, and gain of C-band HPA vs. input power (frequency = 5.7 GHz, VDS = 35 V, pulse width = 100 μs, and duty factor = 10%).

in Fig. 6, over a range of 5.5 GHz to 6.2 GHz. The input power is fixed to 30 dBm. The output power is from 46.7 dBm to 47.2 dBm, while the power efficiency varies between 35% and 42%. At an input power of 30 dBm, the output power variation is less than 0.5 dB over the frequency range. At the saturated power level, the DC current was measured as 4.1 A.

The output power, gain, and PAE, all of which are as a function of input power are shown in Fig. 7. The peak power is 50 W with a higher than 35% PAE and 17 dB associated gain at a 5 dB gain compression.

An IR temperature image was measured at a continuous DC supply of VDS = 30 V, ID = 1.39 A, with a power dissipation of 3.5 W/mm, which is a similar condition to the previous reported X-band 50 W HPA (3 W/mm) [1]. The base plate temperature is 80°C, which is known as the upper limit of the operation temperature. The junction temperature is measured

Table 1. Comparison of C-band power amplifier MMICs.

Reference	Technology	Freq. (GHz)	Pout (dBm)	PAE (%)	Gain (dB)	Vd (V)	Pout/area (W/mm ²)	Area (mm ²)	Pulse/duty (μs/%)
This work	0.25 GaN HEMT	5.5 – 6.2	46.7 – 47.2	35 – 42	22.0	35.0	3.2 – 3.5	14.8	100/10
[2]	0.25 GaN HEMT	5.2 – 6.2	42.1 – 43.0	31 – 41	20.0	30.0	1.0 – 1.3	15.8	100/30
[3]	0.25 GaN HEMT	5.5 – 8.5	45.9 – 46.3	38 – 45	22.0	28.0	2.3 – 2.5	17.3	1000/0.1
[4]*	0.25 GaN HEMT	2.5 – 6.0	44.8 – 46.2	31 – 41	27.0	30.0	-	-	300/10
[7]	GaAs HBT	4.7 – 6.0	41.8 – 42.4	31 – 41	18.0	8.5	0.3	60.0	100/10
[8]	0.5 GaAs pHEMT	4.9 – 6.1	44.3 – 44.9	30 – 35	16.5	14.0	1.0 – 1.1	27.2	20/2

*Packaged HPA

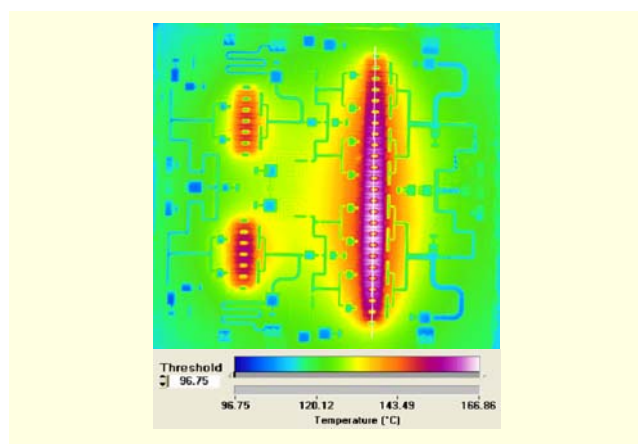

Fig. 8. IR image at condition of VDS = 30 V, ID = 1.39 A. Power dissipation is 41.7 W. Base plate temperature is 80°C.

as 166.9°C, as shown in Fig. 8, which is much lower than the maximum rating junction temperature of Cree (225°C) [3] and TriQuint (275°C) [4].

Table 1 shows the summarized 50 W HPA characteristics and comparisons with other works. Commercial GaN HPA products, some HPAs using a GaAs HBT [7] and HEMT [8] process covering the C-band, and a previously reported paper are compared with our work. From the table, it can be observed that the maximum output power and the power density of our works are better than in other designs.

IV. Conclusion

In this letter, we presented a C-band 50 W high-power monolithic power amplifier for C-band radar applications. The amplifier demonstrated a saturation output power of 47 dBm and higher than 35% PAE with an output power density of 3.2 W/mm². We believe that this chip with high power and a

small chip size will be a good candidate for realizing C-band phased-array radar systems.

References

- [1] C. Costrini et al., “50W X-Band GaN MMIC HPA: Effective Power Capability and Transient Thermal Analysis,” *Proc. European Microw. Integ. Circuits. Conf.*, Paris, France, Sept. 27–28, 2010, pp. 408–411.
- [2] C. Florian et al., “A C-Band AlGaIn-GaN MMIC HPA for SAR,” *IEEE Microw. Wireless. Compon. Lett.*, vol. 22, no. 9, Sept. 2012, pp. 471–473.
- [3] Cree, *CMPA5585025D, Data sheet*. Accessed Aug. 13, 2013. <http://www.cree.com/~media/Files/Cree/RF/Data%20Sheets/CMPA5585025D.pdf>
- [4] TriQuint, *TGA2576-FL Data Sheet*. Accessed Aug. 13, 2013. <http://www.triquint.com/products/p/TGA2576-FL>
- [5] Cree, *Foundry Manual for GaN HEMT MMIC Design*, ver. 2.0, Apr. 30, 2012.
- [6] J.-C. Jeong, D.-P. Jang, and I.-B. Yom, “A Ka-Band 6-W High Power MMIC Amplifier with High Linearity for VSAT Applications,” *ETRI J.*, vol. 35, no. 3, June 2013, pp. 546–549.
- [7] M.R. DeHaan et al., “A 15-Watt Dual Band HBT MMIC Power Amplifier,” *IEEE MTT-S Int. Microw. Symp. Dig.*, Denver, CO, USA, vol. 3, June 8–13, 1997, pp. 1425–1427.
- [8] S. Lavanga et al., “High Voltage Breakdown pHEMTs for C-Band HPA,” *Proc. European Microw. Integ. Circuits Conf.*, Paris, France, Sept. 27–28, 2010, pp. 142–145.